

TEST AND MEASUREMENT FOR RADIO COMMUNICATION EQUIPMENT

Thomas Boegl
Director of Technology and Studies
DL9MDB

ROHDE & SCHWARZ

Make ideas real



OVERVIEW PART 1

- I Frequency ranges and their role for radio communication**
- I Introduction to typical radio communication equipment and systems of Rohde & Schwarz**
 - I Use cases and derived requirements
 - I State of the art technology
 - I System layouts with focus on RF
- I A look into typical data sheets of communication radios**
 - I Typical receiver data
 - I Typical transmitter data
 - I (short) introduction of applicable standards and their T&M setup e.g.
 - EN300676
 - ARINC716
 - NATO STANAG Standards
 - ITOP

OVERVIEW PART 2

I Short overview of relevant modulation schemes

- I Analogue modes AM, FM und PM (very useful for T&M on communication radios!)
- I Digital modes – Single Carrier and Multi-Carrier waveforms

I Selection of applicable test equipment

- I In Germany we say: Wer misst, misst Mist!
- I What can we do in cases where the DUT is better than the test equipment?

I Receiver measurements (with examples)

- I Sensitivity
- I Desensitization
- I Cross-modulation
- I Intermodulation

OVERVIEW PART 3

I Transmitter measurements

- I Undesired emissions → Transmitter noise, discrete signals
- I Definition of output power (PEP, effective, Carrier)
- I Effect of VSWR

I System measurements

- I Effect of isolation between transmitter and receiver and its relevance for practical use

TYPICAL FREQUENCY RANGES AND THEIR IMPORTANCE FOR COMMS

The electromagnetic spectrum is extremely wide!

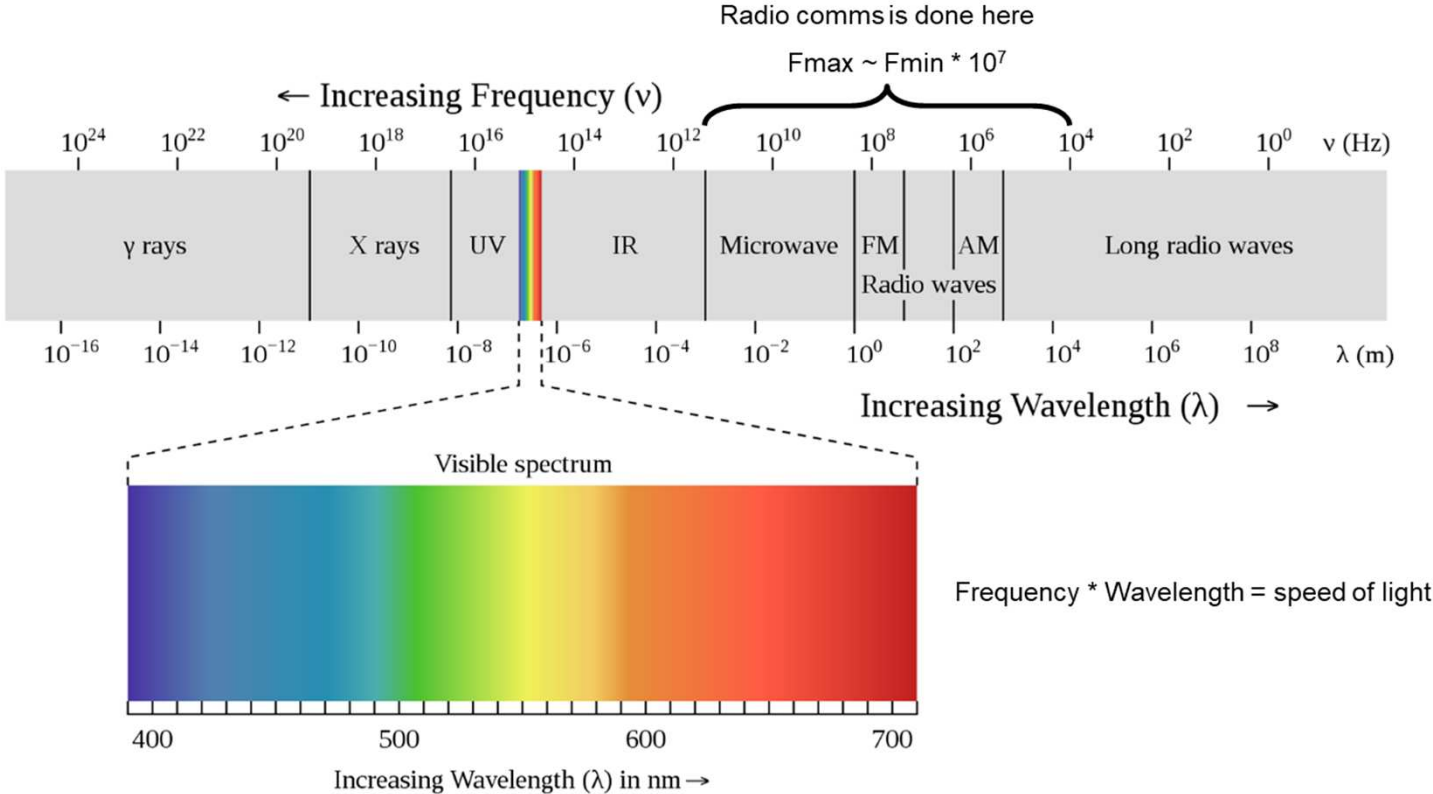

TYPICAL FREQUENCY RANGES AND THEIR UTILIZATION

A simplified structure for frequency bands used for radio communication

Frequency or frequency band	Wavelength	Classical band designator	Practical band designator	Typical use cases
50Hz	6000km	none	Mains frequency	Energy distribution, wired, no comms, but very RF due to large dimensions
Typ. 10kHz	30km	LF = Low Frequency	Very/extremely long wavelength	Comms for Submarines
1.5MHz – 30MHz	200m – 10m	HF = High Frequency	Shortwave	Global comms via skywave Use of ionospheric effects
30MHz – 300MHz	10m – 1m	VHF = Very High Frequency	VHF, UHF, ATC	LOS (line-of-sight) by using ground waves
300MHz – 3000MHz	1m – 0.1m	UHF = Very High Frequency	Div. designators	LOS comms Increased bandwidths
3000MHz – "some" GHz	Down to mm range or even less	SHF = Super High Frequency	Div. designators for individual subbands	Radar, medical technology, directional links and much more

LET'S LOOK INTO THE PRACTICAL USE SIMOP SIMULTANEOUS OPERATION - COLLOCATION

Many Systems have to work fully in parallel due to flight safety.
This is a challenge for the RF designers



LET'S LOOK INTO THE PRACTICAL USE SIMOP SIMULTANEOUS OPERATION - COLLOCATION

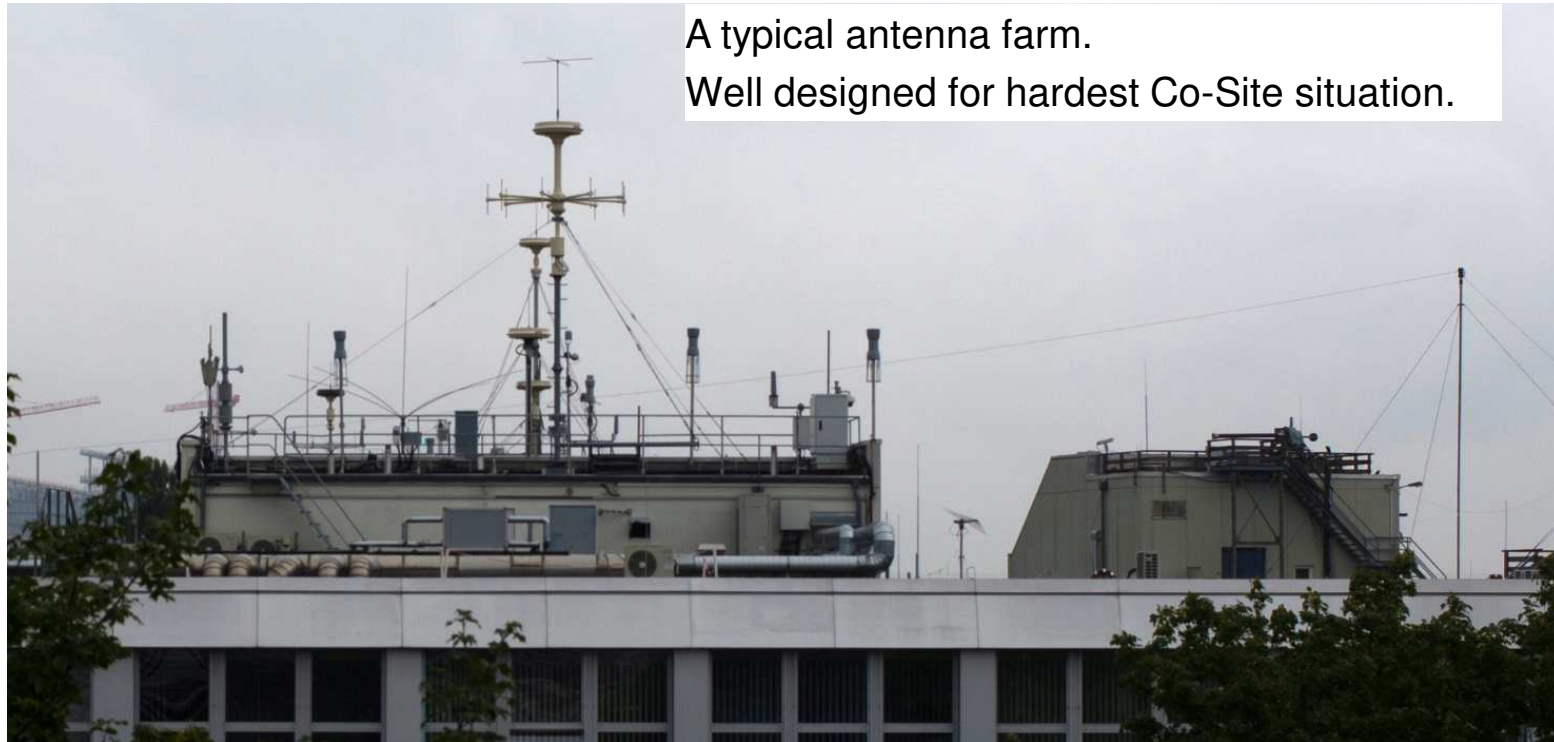

A typical antenna farm.
Well designed for hardest Co-Site situation.

PRACTICAL VIEW

AN EXAMPLE FOR THE RECEIVER DATA SHEET – SOME TYPICAL DATA

The radio shall have the following Sensitivity

for A3E, m =30 %	≤-105 dBm, for 10 dB (S+N)/N, unweighted
for F3E, Δf=2.4 kHz	≤-113 dBm, for 10 dB (S+N)/N, unweighted

The radio shall have the following Image Rejection

TVHF range 30 MHz to 87.975 MHz *1)	≥100 dB
VHF range 108 MHz to 173.975 MHz	≥100 dB
UHF range 225 MHz to 399.975 MHz	≥100 dB
all other frequencies	≥ 65 dB

The radio shall have the following Cross Modulation / Blocking Rejection

The undesired cross modulation product is down at least 20 dB (10 %) relative to the audio output. Values specified are relative to maximum sensitivity level -105 dBm

for Δf ≥100 kHz	≥ 90dB
for Δf ≥2 %	≥100 dB

In ATC VHF range 118 MHz to 136.975 MHz according to ARINC 716

for Δf ≥ 2 MHz	≥120 dB (≥ +15 dBm)
----------------	---------------------

The radio shall have the following 3rd Order Intermodulation Rejection

for spacing 2/4 up to 40/80 channels	≥ 76 dB
--------------------------------------	---------

The radio shall have the following IF Rejection

≥100 dB

*1): TVHF = tactical VHF

PRACTICAL VIEW

AN EXAMPLE FOR A TRANSMITTER DATA SHEET – SOME TYPICAL DATA

The radio shall have the following RF Output Power

≥ 20 W AM carrier / ≥ 30 W FM

The radio shall have the following TX power steps

High:	≥ 20 W AM	≥ 30 W FM
Medium:	2 W to 4 W AM	3 W to 6 W FM
Low:	0.2 W to 0.4 W AM	0.3 W to 0.6 W FM

The radio shall have the following VSWR power reduction

at VSWR = 2, all phases	≤ 1 dB
at VSWR = 3, all phases	≤ 2 dB
for VSWR > 3	Transmitter shall stay operational with reduced power >3 W

The radio shall provide protection against VSWR, all phases

In case of extreme antenna mismatch the radio reduces the output power to >3 W
The transmitter shall withstand extreme antenna mismatch without damage.

INTRODUCTION OF APPLICABLE STANDARDS AND THEIR T&M SETUP

- I Radio standards are focused on particular use cases and are normally only applicable for a very specific use**
- I Looking to "all" standards, we see significant differences with respect to**
 - I requirements
 - I definition of these requirements
 - I How these requirements can or must be measured
- I Some standards inherently define their applicability**

INTRODUCTION OF APPLICABLE STANDARDS AND THEIR T&M SETUP

- ▶ **EN Standards (European Norm) are very often well written in an informative manner and are often taken as reference for purchasing programs**
 - EN300676 → Ground-based VHF hand-held, mobile and fixed radio transmitters, receivers and transceivers for the VHF aeronautical mobile service using amplitude modulation; → ATC GND stations
- ▶ **ARINC → Air Radio Incorporated = US company, creation and maintenance of technical standards for airborne equipment**
 - ARINC716 → AIRBORNE VHF COMMUNICATIONS TRANSCEIVER → Avionic equipment
- ▶ **STANAG → Standarisation Agreement = NATO Standards describing requirements to achieve Interoperability (military standard)**
 - STANAG 4205 → TECHNICAL STANDARDS FOR SINGLE CHANNEL UHF RADIO EQUIPMENT
- ▶ **ITOP → International Test Operations Procedure (military standard)**
 - Description of helpful test procedures, helpful in some discussions among experts

TECHNICAL PARAMETERS WITHIN RADIO COMMUNICATION MODULATION

Goal of Modulation:

- ▶ Place the content of a message onto a previously unmodulated radio signal.
- ▶ This modulated signal carries this message to the receiver (in former days: → "carrier signal").
- ▶ Modulation simply means, that we modify the signal sent to the receiver in a way that the receiver can recognize the message within.
- ▶ We can either vary or "modulate" the level of the signal and/or it's characteristic.
- ▶ The most simple type of modulation is on/off keying → Morse telegraphy.
- ▶ Modern modulation schemes modulate the level, frequency and phase of the radio signal simultaneously and in combination. This not only allows us to transfer messages to the receiver; it also assures a narrow bandwidth requirement.

TECHNICAL PARAMETERS WITHIN RADIO COMMUNICATION

ANALOGUE AND DIGITAL MODULATION SCHEMES

Analogue Modulations:

- ▶ Modulations methods are „analogue" if the radio signal is continuously varied as an analogue of the information signal.
- ▶ "Analogue" also means that for each intermediate electrical state which can be impressed upon the radio signal, a corresponding intermediate electrical state of the information signal exists.
- ▶ In cases where e.g. an analogue tone signal is modulated (= AC signal with an audio frequency) the RF signal is varied either in level, frequency or phase according to the "rhythm" of the tone

Comment:

- ▶ Analogue Modulation is processed by means of digital circuits today e.g. DSP.
- ▶ Nonetheless, analogue modulation schemes remain analogue.

TECHNICAL PARAMETERS WITHIN RADIO COMMUNICATION

ANALOGUE AND DIGITAL MODULATION SCHEMES

Digital Modulations:

- ▶ Modulations methods are called digital if discrete states of the RF signal correspond to discrete states of the information signal.
- ▶ The states of the information signal are normally the logical 1 or 0 or combinations of these.
- ▶ Combinations are called "symbols".
- ▶ A classical digital modulation scheme switches e.g. the phase of the carrier signal between two states depending on the state of the logical 1 or 0 of the information signal. This is termed "two phase modulation" or Binary Phase Shift Keying BPSK.

TYPICAL MODULATION SYSTEMS AND THEIR APPLICATIONS

Mode	Modulation principle	Examples for typical application	typ. ITU-R emission designators
AM	Classical analogue amplitude modulation	<ul style="list-style-type: none"> Civil ATC and AM broadcasting 	A3E
SSB	Single Sideband = "modified AM"	<ul style="list-style-type: none"> Voice and Data transmission on HF 	J3E, J7B
FM	Classical analogue frequency modulation	<ul style="list-style-type: none"> VHF tactical military and land-mobile radios VHF broadcasting 	F3E, F8E
PM	Analog phase modulation	<ul style="list-style-type: none"> VHF maritime communications 	G3E
N - PSK BPSK QPSK 8-PSK	Switching the Phase depending on combinations of bits or symbols PSK = Phase Shift Keying BPSK = binary Phase Shift Keying QPSK = quaternary Phase Shift Keying 8-PSK = 8 symbols as combination of 3 bits	<ul style="list-style-type: none"> Satellite communications General digital communications VDL = VHF Data link = ATC data link <p>Comment: the special characteristic of PSK is the fact that all symbols have the same power (all on a circle)</p>	G7W
QAM 16 QAM N-QAM	Quadrature Amplitude Modulation	<ul style="list-style-type: none"> Digital Modulation modes for various waveforms 	X7D
OFDM	Multi--carrier signal with digitally modulated subcarriers	<ul style="list-style-type: none"> Fading robustness DAB, DVB-T and others 	X7E, X7F

TYPICAL MODULATION SCHEMES AND THEIR CHARACTERISTICS

AM – WITHIN THE TIME DOMAIN

modulation signal = information signal → Envelope of the modulated RF signal

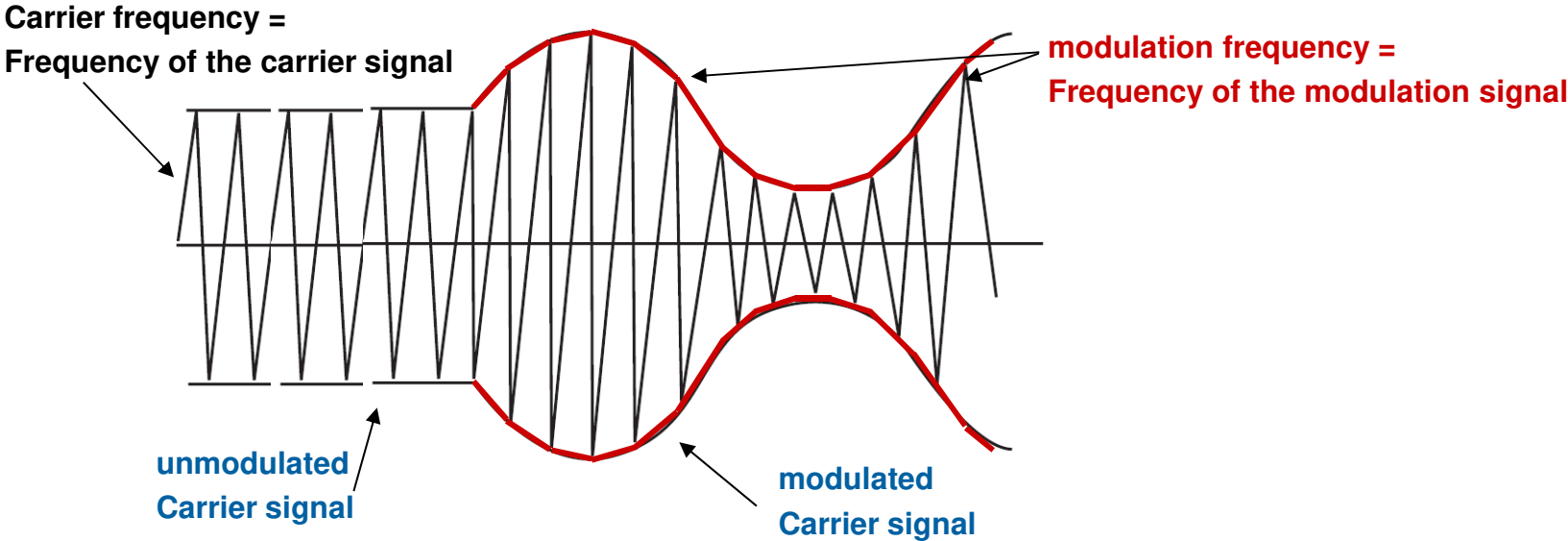

TYPICAL MODULATION SCHEMES AND THEIR CHARACTERISTICS

AM – WITHIN THE TIME DOMAIN

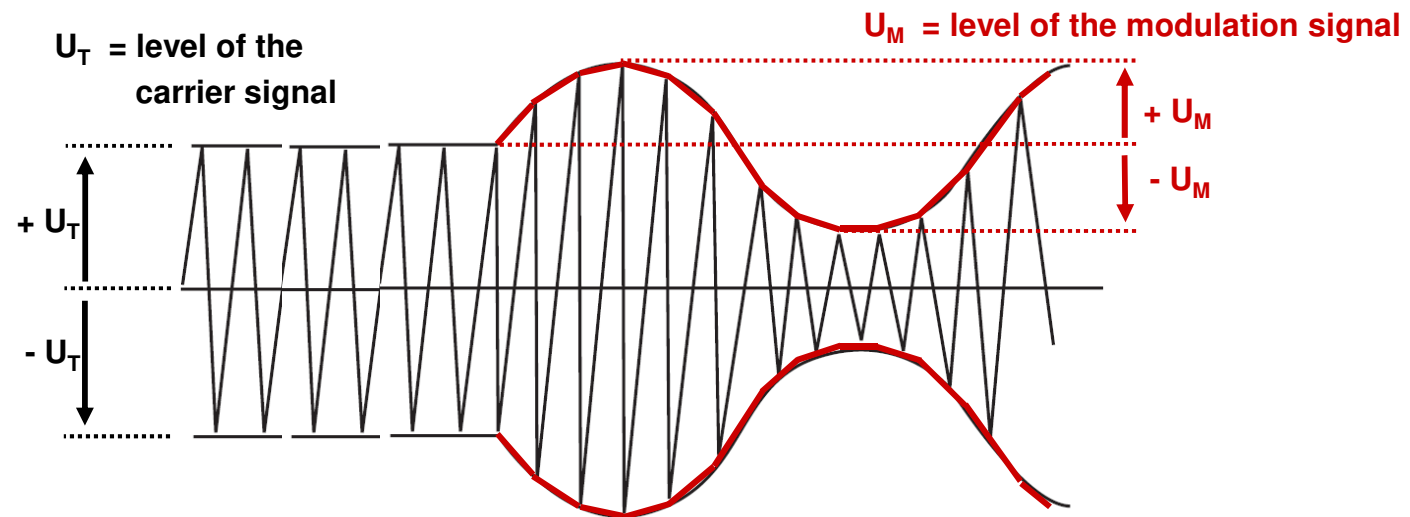

$$U_M = U_T * m \quad \rightarrow m = \text{modulation index}$$

- I "m" is normally between 0 and 1 (100%). It is sometimes described as "percentage modulation".
- I $m > 100\%$ is also existing, but does not have a significant relevance for radio communication
- I For $m = 1$ the maximum possible level is twice the level of the unmodulated carrier signal.
- I AM modulated signals show more transmit power than an unmodulated signal

TYPICAL MODULATION SCHEMES AND THEIR CHARACTERISTICS

AM – WITHIN THE SPECTRUM DOMAIN

AM spectrum with the following settings:

- I Modulation frequency : 1kHz (without harmonics)
- I Modulation index $m = 0.3$ (30%)

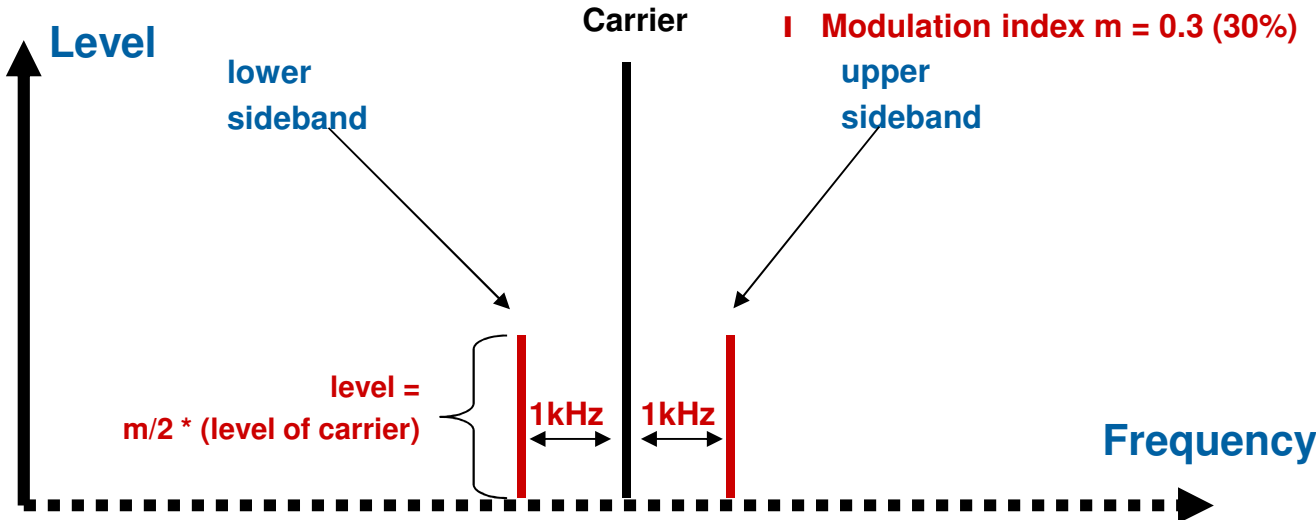

- I At $m = 0.3$ the sideband has 15% of the carrier level → the sideband is 16.5dB below the carrier level.
- I If the modulation signal is free of any harmonics then a sideband consists only of a single line.

TYPICAL MODULATION SCHEMES AND THEIR CHARACTERISTICS

AM

► Advantages of AM

- Easy to generate – the simplest form of AM is switching the carrier on and off → Morse telegraphy.
- Simple to demodulate – basically only a diode required
- AM is a so called "linear modulation method"; this means that all differences in levels between different signals are equal through the complete receiver chain. This facilitates AM test and measurement on receiver structures.
- Marrow spectrum → bandwidth approx. \pm modulation frequency.

► Disadvantages of AM

- Transmitters must be able to provide levels up to twice the carrier signal amplitude, which corresponds to four times the power.
- The variation of the envelope amplitude requires transmitters to be linear, otherwise the modulation signal may be distorted.
- Variations of the radio signal between the antennas may strongly influence the transmission quality .

TYPICAL MODULATION SCHEMES AND THEIR CHARACTERISTICS

FM – WITHIN THE TIME DOMAIN

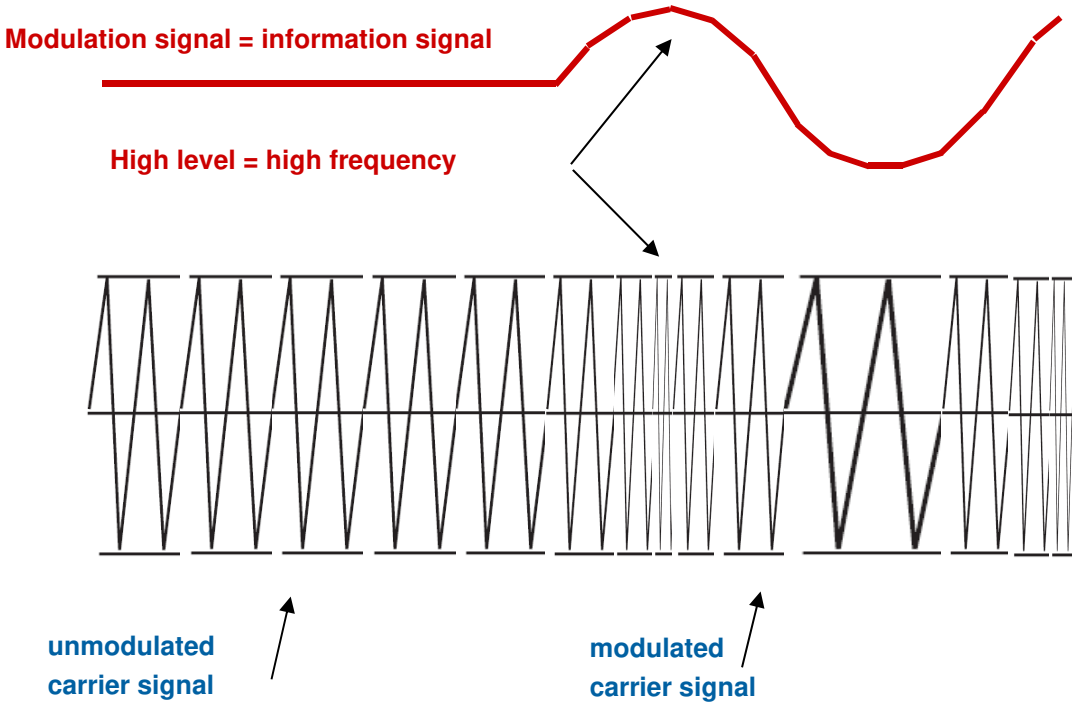

TYPICAL MODULATION SCHEMES AND THEIR CHARACTERISTICS

FM – WITHIN THE TIME DOMAIN

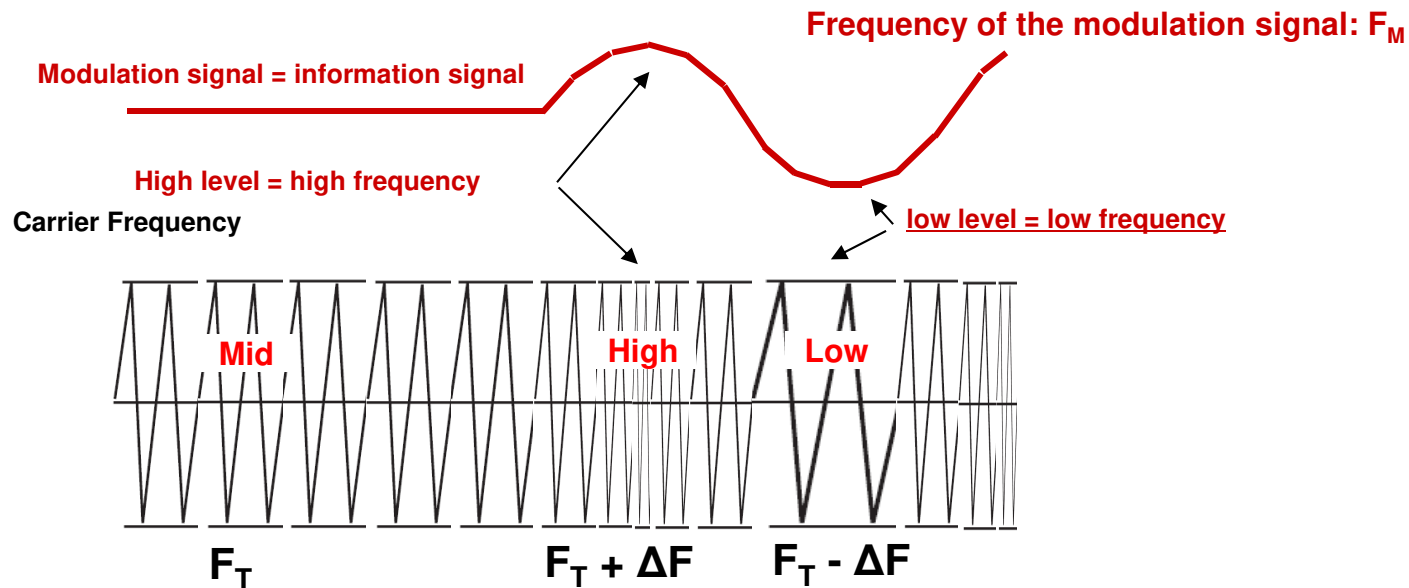

- I The parameter corresponding to the modulation index in AM is the modulation index β in FM.
- I The modulation index describes the relation between the variation of the carrier frequency (ΔF caused by the modulation signal) and the frequency of the modulating signal F_M .
- I $\beta = \Delta F / F_M$

TYPICAL MODULATION SCHEMES AND THEIR CHARACTERISTICS

FM – WITHIN THE SPECTRUM DOMAIN

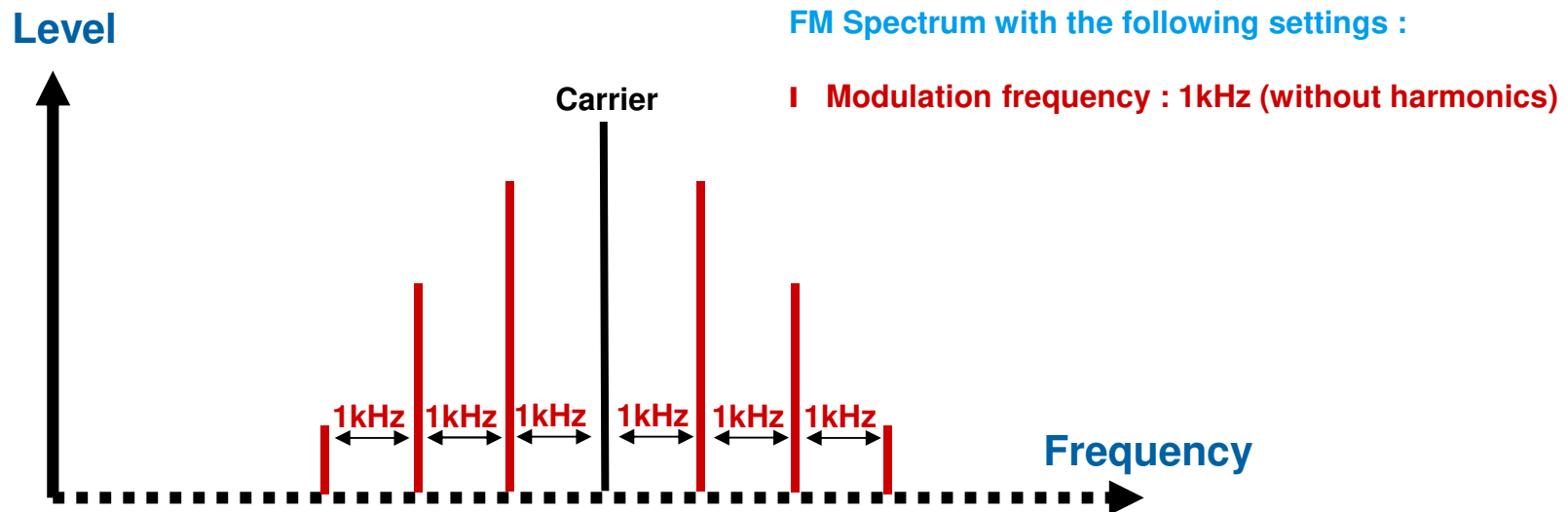

- The FM spectrum not only contains two lines; it basically contains an infinite number of them.
- All lines are equally spaced; the spacing is the modulation frequency.
- The number and level of particular lines are described by the so called "Bessel Function".
- The total power of all lines (carrier plus sidebands) is constant.
- This means that the carrier may disappear at particular values of the modulation index (*Bessel nulls*).

TYPICAL MODULATION SCHEMES AND THEIR CHARACTERISTICS

FM – WITHIN THE SPECTRUM DOMAIN

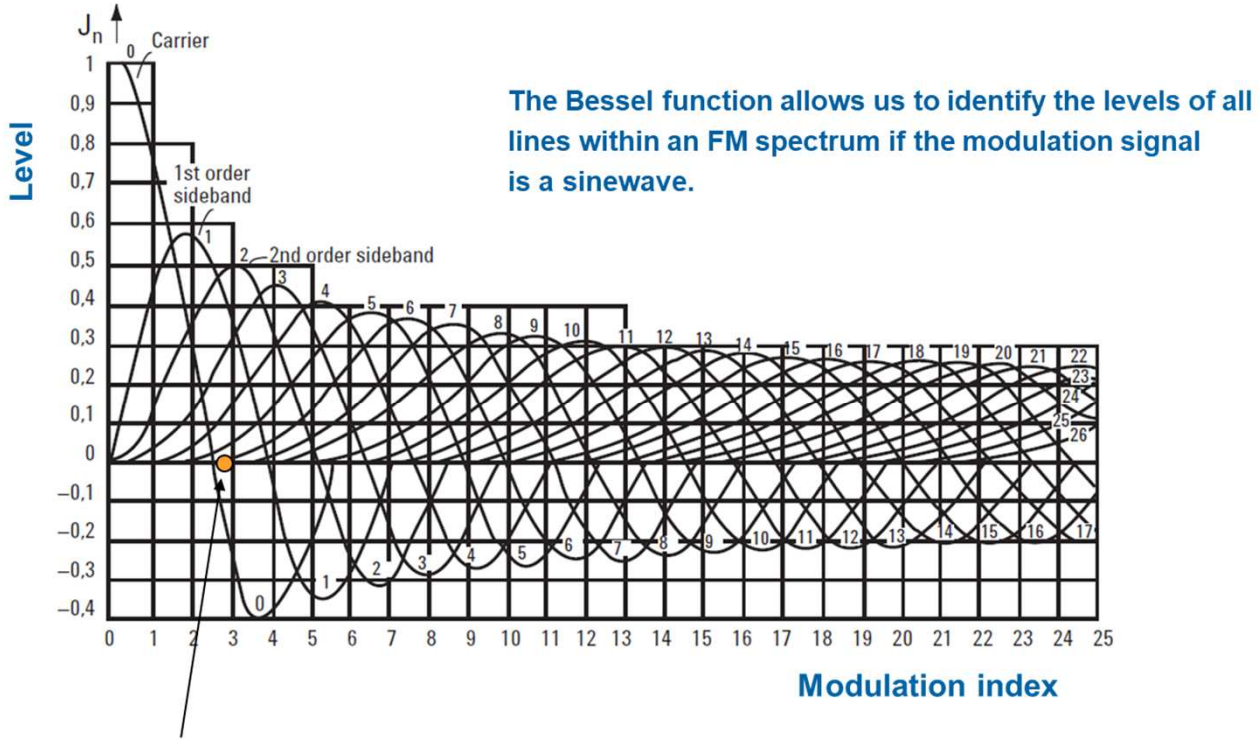

At a modulation index of approx. 2.4 the carrier disappears (1st Bessel null).

TYPICAL MODULATION SCHEMES AND THEIR CHARACTERISTICS

FM

► Advantages of FM

- It's a so called non-linear modulation method → variations in RF level do not affect the levels at the output of a receiver.
- High quality of analogue modulation e.g. FM broadcast
- High receiver sensitivity achievable (sensitivity versus bandwidth).
- Constant envelope amplitude
- Non-linear transmitters (e.g. Class C) are usable, allowing high transmitter efficiencies.
- Receiver suppresses incidental AM and AM noise when receiver's limiters are driven into saturation (fully-quieted).

► Disadvantages of FM

- At the beginning of radio communication technology, FM was more difficult to demodulate than AM.
- Higher occupied bandwidth required than for AM.

TYPICAL MODULATION SCHEMES AND THEIR CHARACTERISTICS

INTRODUCTION TO DIGITAL MODULATION

- I Digital modulation systems link the information (bits or symbols) to a particular phase and amplitude of the carrier signal.
- I So-called differential modes link the information (bits or symbols) to a transition between two states of phase and amplitude of the carrier signal.
- I The bandwidth of the signal is determined by the "smoothness" of all transitions between different states of phase and amplitude of the carrier

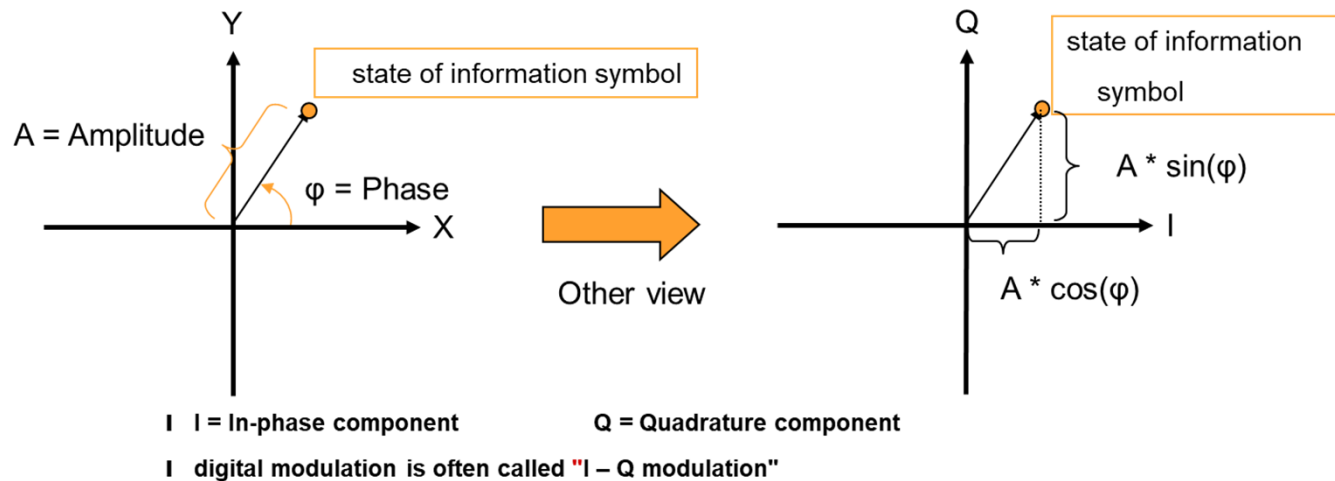

TYPICAL MODULATION SCHEMES AND THEIR CHARACTERISTICS

INTRODUCTION TO DIGITAL MODULATION

- I The bandwidth of the signal is determined by the "smoothness" of all transitions between different states of phase and amplitude of the carrier
- I Small bandwidths can be achieved by using a smooth transition of phase and amplitude in a well coordinated manner
- I Uncordinated phase or amplitude changes can influence this well-defined process in such a way as to cause spectral regrowth

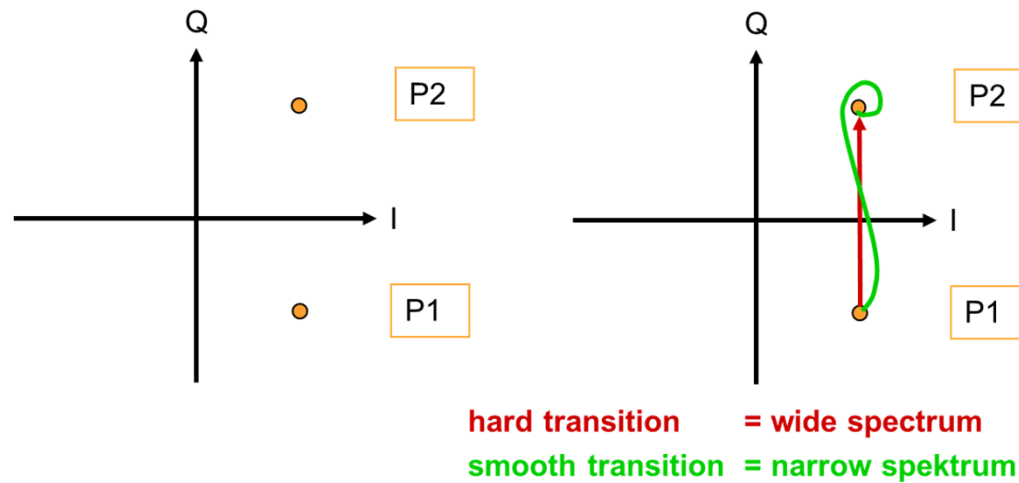

TYPICAL MODULATION SCHEMES AND THEIR CHARACTERISTICS

INTRODUCTION TO DIGITAL MODULATION

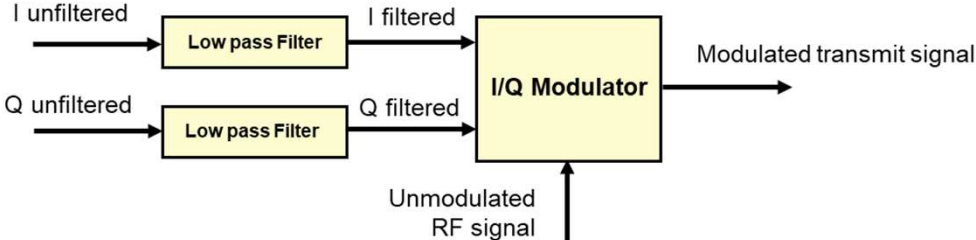

LP Filter =
Root raised Cosine Filter
 $\alpha = 0.5$

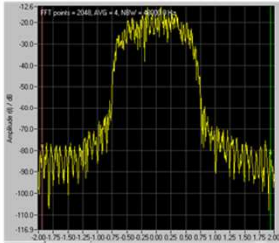
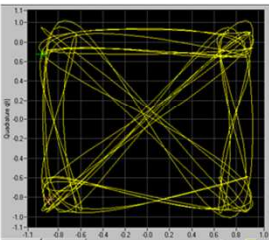

TP Filter =
No filter

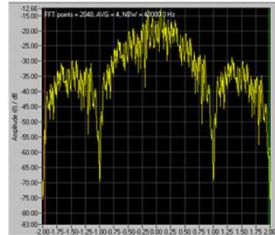
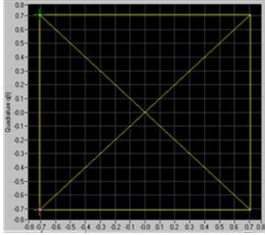

Same symbol rate but
significantly different
bandwidth and spectrum

TYPICAL MODULATION SCHEMES AND THEIR CHARACTERISTICS

N-PSK

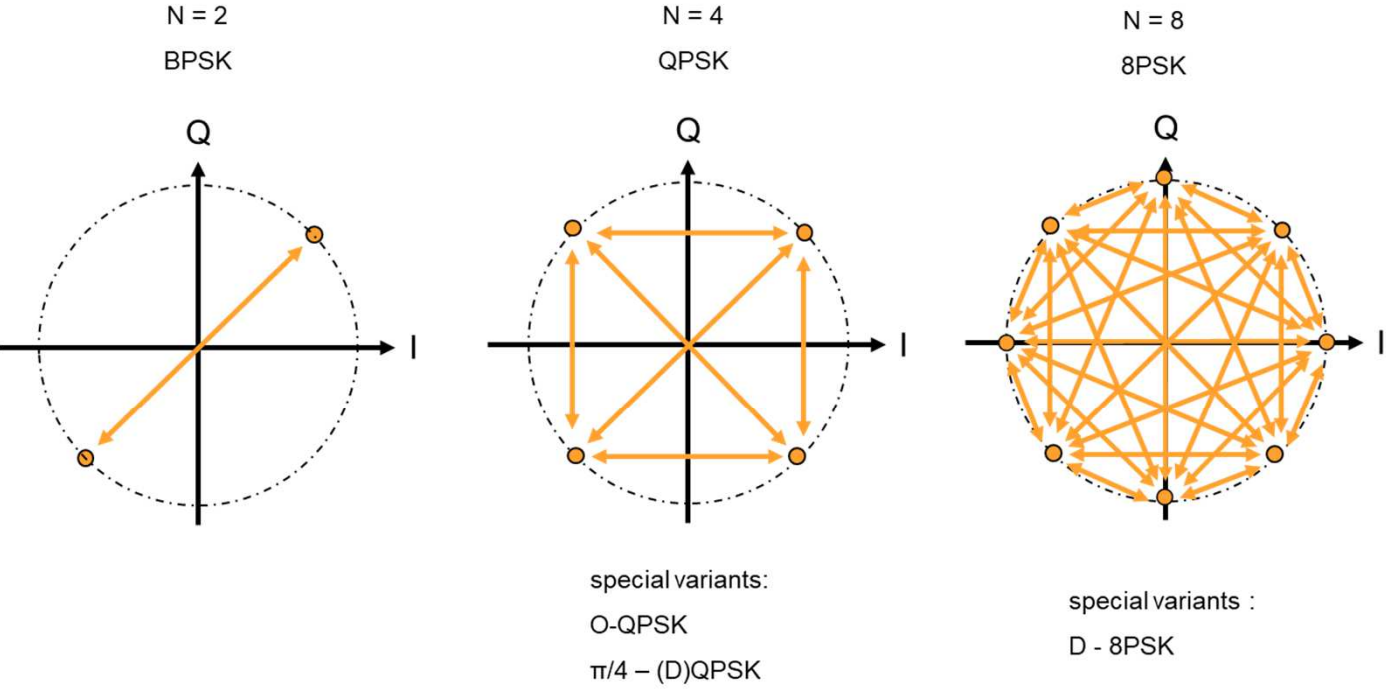

- I For N-PSK modulation all symbols are located on a circle.
- I The receiver detects only the phase difference between symbols

TYPICAL MODULATION SCHEMES AND THEIR CHARACTERISTICS

N-QAM

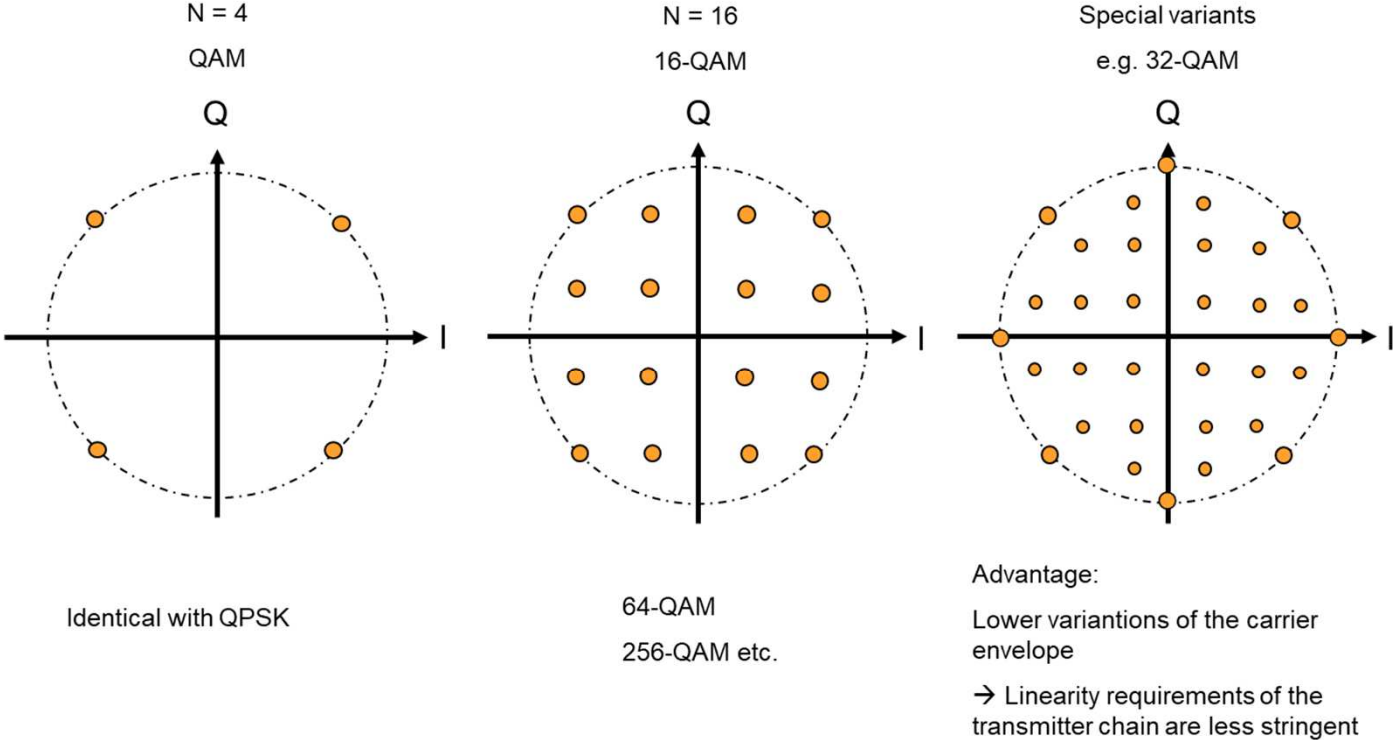

TYPICAL MODULATION SCHEMES AND THEIR CHARACTERISTICS

OFDM

► Purpose of OFDM schemes

- The previously shown modulation schemes were so-called "Single-Carrier" waveforms.
- Basically single-carrier waveforms can also be used for high bandwidths.
- Unfortunately, though, over-the-air narrowband signals are affected differently as compared to broadband waveforms
- "Selective fading" can affect and suppress small areas within a channel
- If this suppression occurs at the center of a channel, then the carrier of a single-carrier signal is destroyed.
- OFDM signals use several carriers which share the available channel bandwidth among themselves.
- If selective fading occurs, only some carriers are affected but the remaining ones are unaffected and continue the error-free transmission
- OFDM = Orthogonal Frequency Division Multiple Access means that the individual carriers are "orthogonal" to each other, which makes them basically independent of each other.
- The individual carriers are then modulated with a digital modulation scheme.
- The individual parameters are carefully chosen to reduce crosstalk between the carriers.

TYPICAL MODULATION SCHEMES AND THEIR CHARACTERISTICS

OFDM

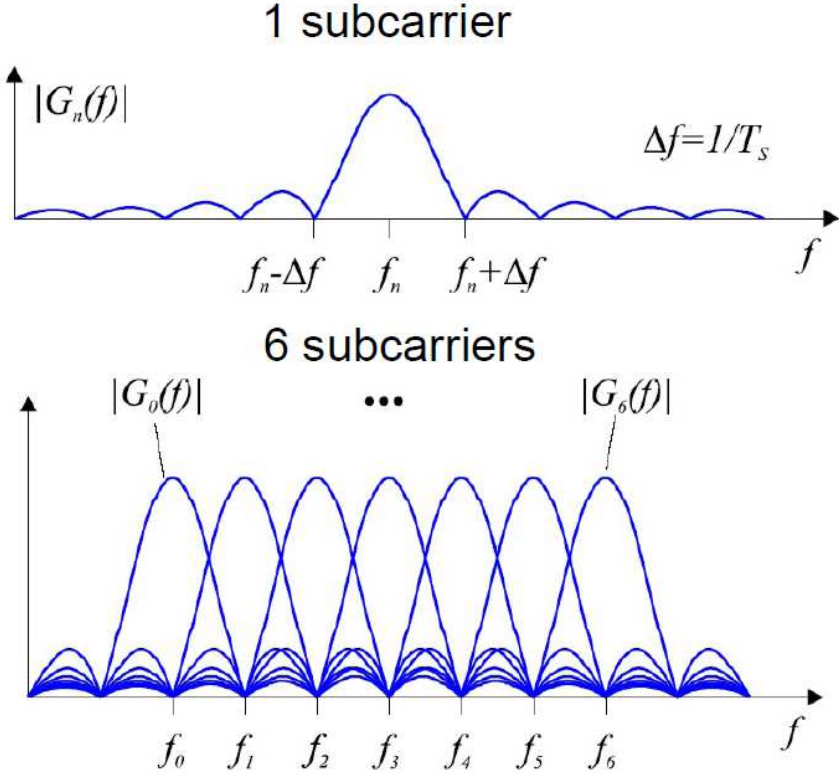

TYPICAL MODULATION SCHEMES AND THEIR CHARACTERISTICS

OFDM

► Advantages of OFDM

- The information content is distributed on many quasi-independent carriers within the channel.
- Highly robust against fading.
- High efficiency with respect to bandwidth by locating the carriers within the "spectrum nulls" of the neighboring carriers.

► Disadvantage of OFDM

- Complex generation and demodulation.
- High doppler effects require carefully designed carrier constellations.
- High crest factor → high peak power while the effective power remains quite low.
- Stringent linearity requirements for the transmitter chain.

REQUIRED TEST EQUIPMENT FOR TYPICAL RF MEASUREMENT

LIST OF REQUIRED EQUIPMENT

▶ Preferred "primary" equipment

- Spectrum analyzer
- Digital Oscilloscope

▶ Additional important equipment

- Signal Generators
- (Optional): Vector Signal Generator or Arbitrary Waveform Generator
- Noise Generators
- Filters
- Amplifiers
- Mixer
- Test Probes

REQUIRED TEST EQUIPMENT FOR TYPICAL RF MEASUREMENT

LIST OF PARAMETERS WE WANT TO MEASURE

- ▶ **Frequency Range**
- ▶ **Sensitivity**
- ▶ **Cross-Modulation**
- ▶ **Level**
- ▶ **Phase Noise**
- ▶ **Desensitization**
- ▶ **Undesired Signals**
- ▶ **Frequency Switching Times**
- ▶ **Additional Tests**
 - ADC Clip Level #54
 - Reciprocal Mixing Dynamic Range (RMDR) #55
 - Interference Free Signal Strength (IFSS) #64
 - Noise Power Ratio (NPR) #66

RECEIVER PARAMETERS

RECEIVER STRUCTURES AND THEIR PARAMETERS

The main tasks for a receiver are :

Receive weak signals

and at the same time

Offer high immunity to interferers of any kind

- I Good receivers receive signals below $1\mu\text{V}$ and are immune to interferers at levels of many volts**
- I The difference between desired and undesired signals may be as much as 150dB e.g. in vehicular systems!**

Beyond this, several more capabilities are (may be) important:

- I Wide frequency range (up to GHz).**
- I Capable of receiving any kind of modulation.**
- I Fast tuning (e.g. for Frequency Hopping).**
- I And more**

Our equipment for today

Equipment for measuring desensitization

Equipment for measuring TX broadband noise

Step Attenuator



Tunable Notch

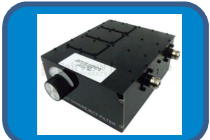

SMR



SMA 100B



CMA180

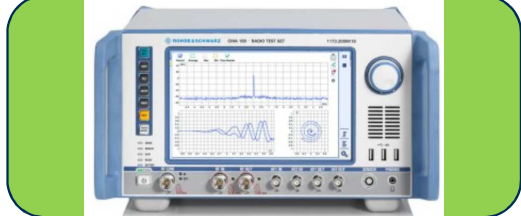

SWP



TESTING SENSITIVITY AND RECEIVER SIGNAL TO NOISE RATIO

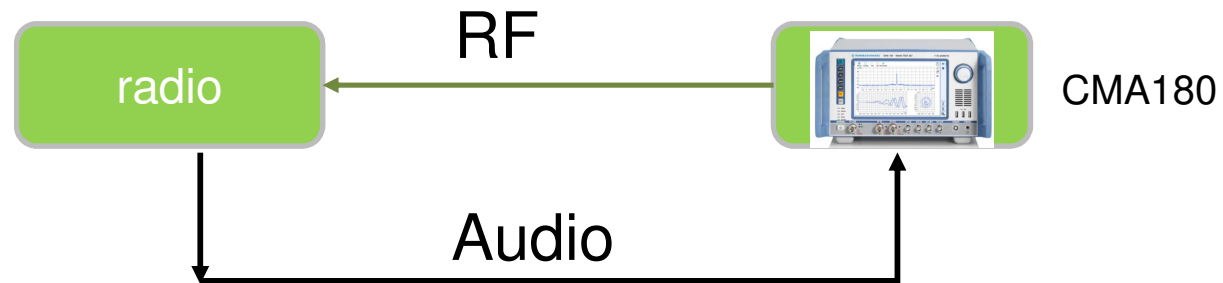

- I Apply an RF signal and feed the audio signal back to the radio communication test set (CMA180)
- I CW ??
- I MDS (Minimum Discernible Signal) ??
- I AM ??
- I 1KHz Audio??
- I 30% modulation
- I S+N/N ??
- I SINAD ??
- I Detailed modulation parameters
- I Audio filter???

TESTING SENSITIVITY AND RECEIVER SIGNAL TO NOISE RATIO

- Very often AM Modulation is helpful because AM allows a very easy analysis of the complete receiver chain (RF to audio)
- A typical standard setting is :1kHz Audio, 30% modulation, for 10dB or 12dB SNR
- S+N/N
 - The modulation is switched on/off by the communication test set.
 - ON: S+N
 - OFF: N
- SINAD (**S**ignal to **N**oise and **D**istortion)
 - The modulation signal is continuously running and an audio notch filter suppresses the 1kHz fundamental → **S**ignal
 - The remainder represents **N**oise and **D**istortion
 - Attention: Higher RF input levels may show some influence caused by audio distortion
 - Conclusion: If SNR will be measured at high RF levels, it is preferable to use S+N/N method
- Audio filter???
 - The bandwidth of the audio signal significantly influences the test result
 - CCITT (ITU-T) Filter, psophometric filter is an audio bandpass filter
 - It allows us to compare the sensitivity of receivers with totally different audio bandwidths
- For digital waveforms, only bit error rate (BER) applies

EVERYTHING EXCEPT SENSITIVITY AND SIGNAL TO NOISE RATIO

- I In cases where not only sensitivity or SNR is to be measured, it is quite likely that errors caused by different effects can appear.**
- I Therefore, it is important to know a little more about the unit under test and its structure to ensure that the test setup is applicable.**
- I Sorry folks, we have to look a little more deeply into some theory.**

TYPICAL PARAMETERS OF RECEIVERS

RECEIVER STRUCTURES – SUPERHET ARCHITECTURE

- I A receiver must fulfil a variety of different parameters
- I e.g. operation with high carrier frequencies (GHz) but often quite low modulation bandwidths (kHz)
- I Good narrowband filtering is only possible at relatively low frequencies (currently several hundred MHz)
- I One receiver design using a mixing process is the superhet architecture
- I Now a few more details

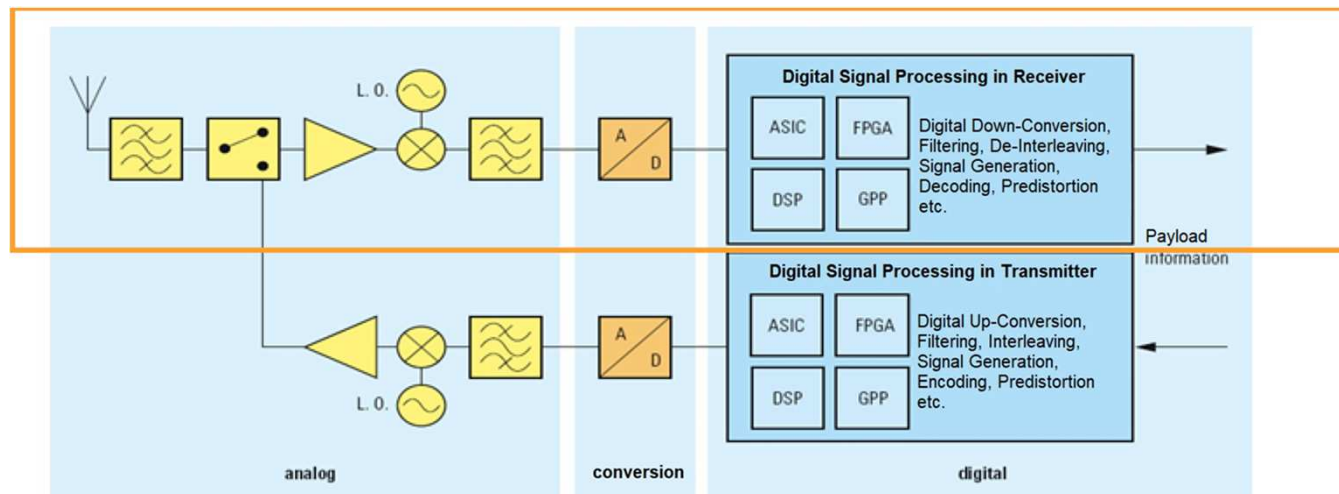

RECEIVER CONCEPTS

SUPERHET CONCEPT AND IMAGE FREQUENCY

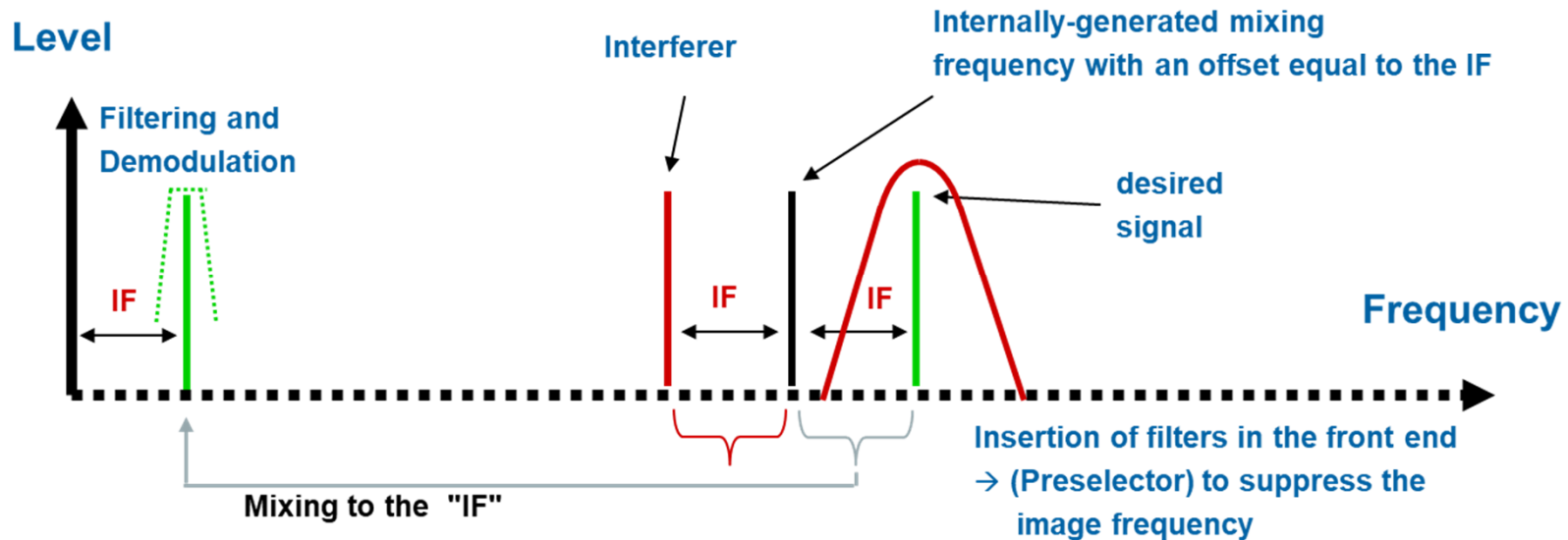

- I In a Superhet, one additional input frequency will be mixed (converted) to the IF. This is the image frequency.
- I The value of *image suppression* in a data sheet indicates how much stronger an interferer on the image frequency must be to be detected at least as strongly as a desired signal
- I The value of *IF suppression* in a data sheet indicates how much stronger an interferer equal in frequency to the IF must be so as to be detected at least as strongly as a desired signal

IMAGE FREQUENCY SUPPRESSION

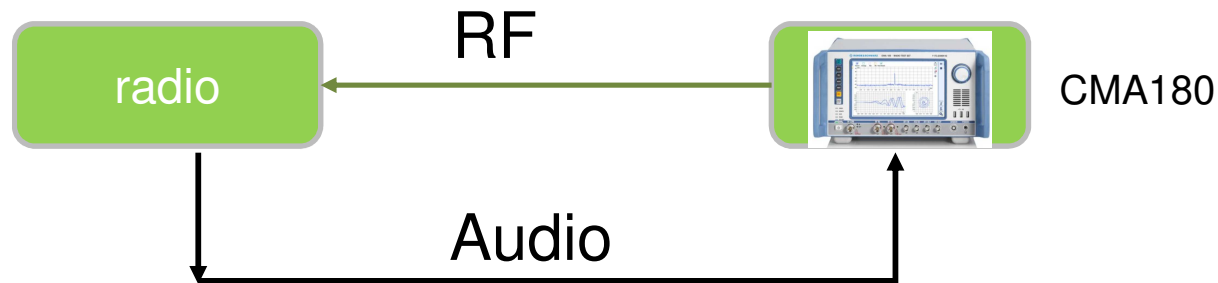

- I Apply an RF signal and feed the audio signal back to the radio communication test set (CMA180)
- I Set the signal generator of the CMTA to the image frequency of the radio (which must therefore be known)
- I Increase RF level until an audio signal is heard
- I Deactivate squelch circuits!
- I Increase RF level until a SNR of (TBD) dB is reached
- I Use SINAD method

IFSUPPRESSION

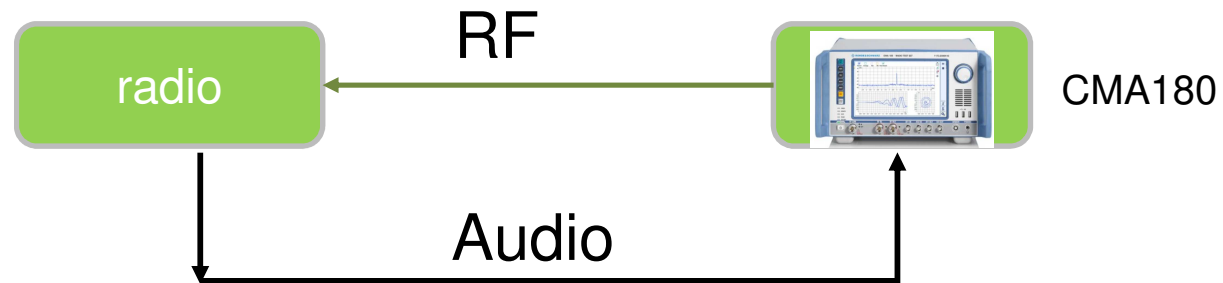

- I Apply an RF signal and feed the audio signal of the radio communication test set (CMA180)
- I Set the signal generator of the CMTA to the IF frequency of the radio (which must therefore be known)
- I Increase RF level until an audio signal is heard
- I Deactivate squelch circuits
- I Increase RF level until a SNR of (TBD) dB is reached
- I Use SINAD method

DESENSITIZATION, CROSS-MODULATION ETC.

- I These are typical parameters which characterize the robustness of a receiver**
- I These values may be beyond the capabilities of a radio communication test set or similar equipment**
- I Let ´ s look at this a little more closely**

DESENSITIZATION

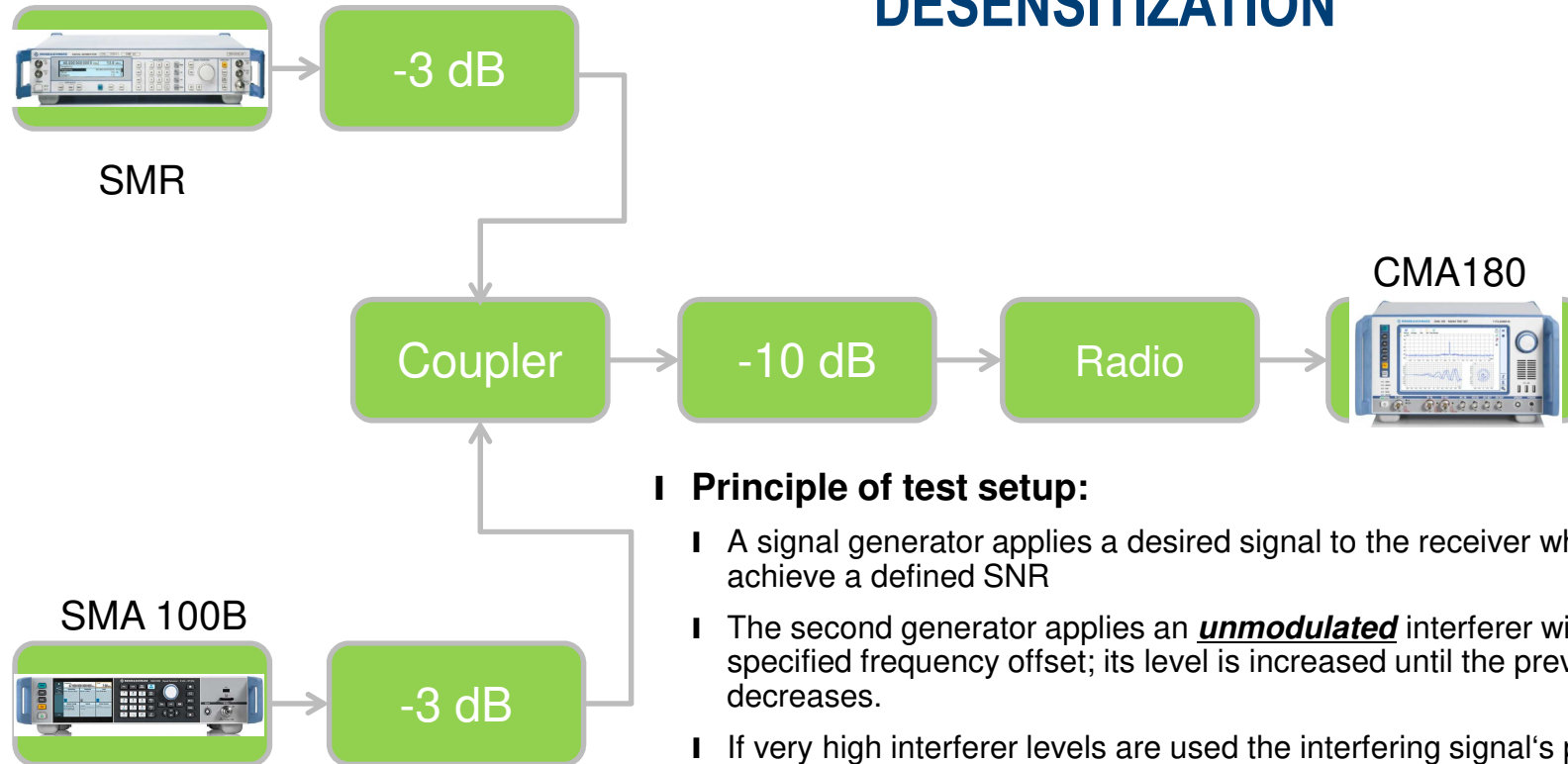

I Principle of test setup:

- I A signal generator applies a desired signal to the receiver which is set to achieve a defined SNR
- I The second generator applies an ***unmodulated*** interferer within a specified frequency offset; its level is increased until the previous SNR decreases.
- I If very high interferer levels are used the interfering signal's phase noise may affect the test result.
- I Using a noisy signal generator as the interferer will corrupt the test result for the D.U.T.

CO-SITE OPERATION: PRACTICAL RX WITH IDEAL TX

DYNAMIC SELECTIVITY (DESENSITIZATION)

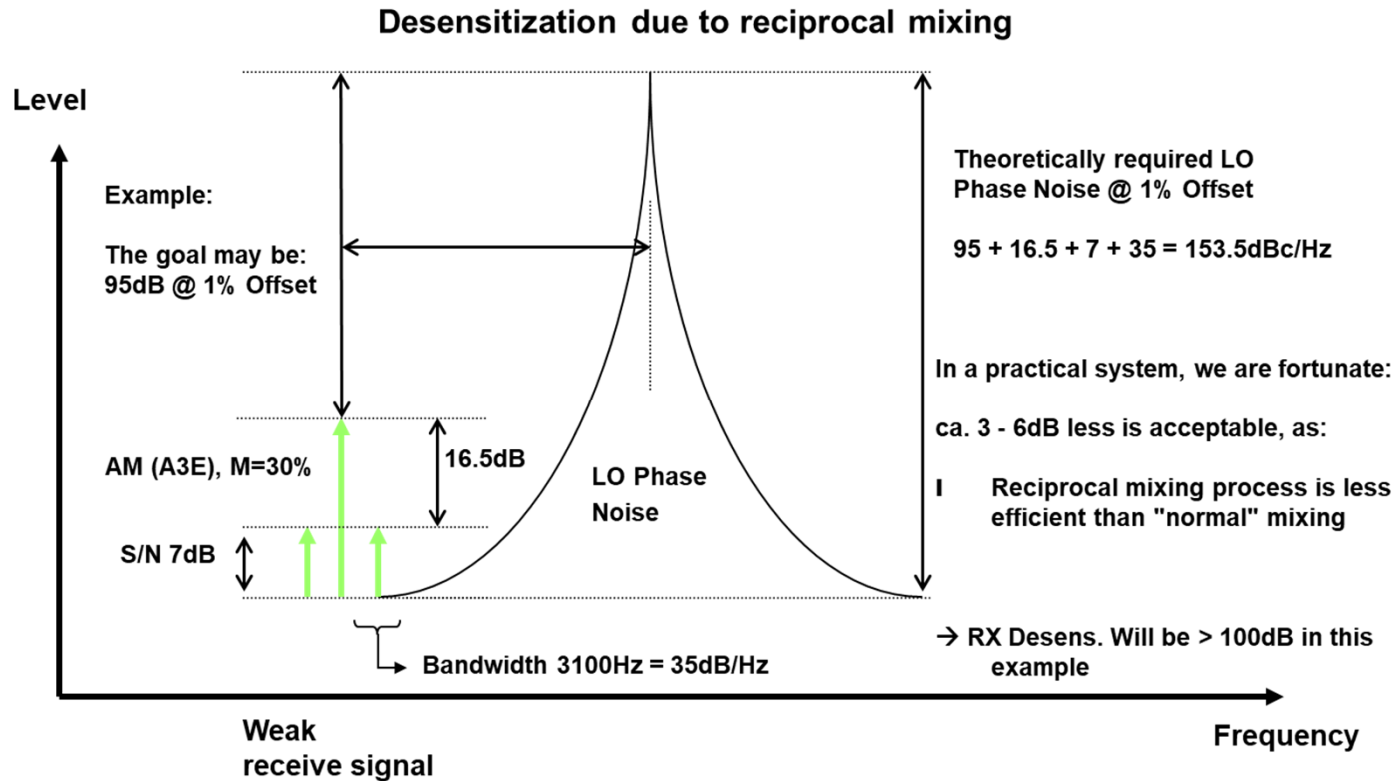

ADC CLIP LEVEL

THE LIMITING CASE FOR INPUT POWER TO A DIRECT-SAMPLING SDR

- In a *direct-sampling SDR receiver*, no blocking occurs until the ADC is driven into saturation (clipping).
 - Thus, we measure and state ADC clip level, **not blocking dynamic range (BDR)**.^{1*}
- ADC clip level: input power at which ADC is at full scale (0 dBFS).
- Typically -8...-12 dBm at RF input, allowing for preselector loss.
 - RF preamplifiers and attenuators off.
- -1 dBFS is the maximum recommended test signal amplitude for linearity tests such as front-end IMD and NPR (Noise Power Ratio).

^{1*}. Even a direct sampling RX has some amplifiers and AGC circuits. If these do not work well we still have “classical” blocking effects. Additionally in co-site scenarios we have a mix of filter selectivity, amplifier capabilities, AGC strategy and finally ADC capability. Also in this case we may have a mix of classical “analogue” effects rather than ADC effects.

RMDR (RECIPROCAL MIXING DYNAMIC RANGE) TEST FOR DIRECT-SAMPLING SDR RECEIVERS



BLOCK DIAGRAM OF RECIPROCAL MIXING TEST SETUP

- I DUT is a direct-sampling SDR receiver. 1*
- I Phase noise of signal source must be 10 dB lower than that of DUT ADC clock source.
- I Test signal source can be high-grade signal generator or low-noise crystal oscillator.
- I f_0 = test frequency; Δf = offset.
- I Test signal freq. = f_0 . DUT tuned to $f_0 - \Delta f$.
- I P_{IN} = input power at f_0 to raise DUT audio output by 3dB.
- I MDS (Minimum Discernible Signal) = input power at $f_0 - \Delta f$ to raise DUT audio output by 3dB.
- I **RMDR = ($P_{IN} - MDS$) dB.**
- I RX phase noise = - (RMDR + 10 log B) dBc/Hz where B = detection bandwidth in Hz.
- I Desensitization = - (RMDR + MDS) dB.
- I Limiting case for P_{IN} is ADC clipping (saturation).

1*. The achievable RMDR purely based on phase noise (which it purely is) may allow much higher level differences between wanted signals and interferers than the ADC alone can withstand. This leads to the following "decisions" for the designer: If I am happy with the ADC performance alone I can relax the phase noise quality inside the receiver to reduce cost. OR: If I want to achieve the technically possible RX performance I will have to assist the ADC by adding filters, amplifiers, AGC etc.

The answer for the right design is given by the user and his use cases.

RECEIVER CONCEPTS

CROSS-MODULATION AND INTERMODULATION → HOW DO WE MEASURE IT?

For an easy modelling of "Cross-Modulation" and "Intermodulation" we split the receive chain into two halves: An ideal "zero - problem" receiver with an "interference effect generator" in front

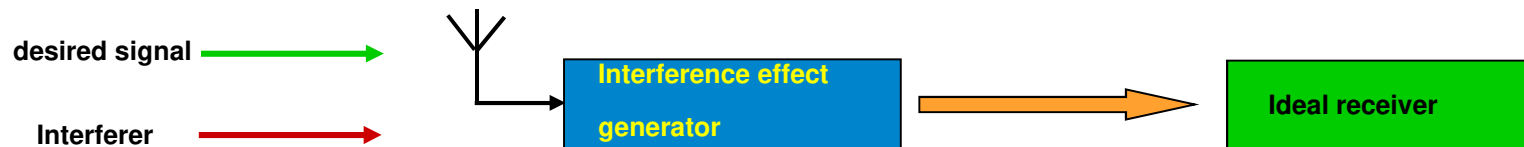

The "interference effect generator" creates the following effects:

- I Unchanged desired signals
- I Modified desired signals
- I New signals in the receive channel (ghost signals)

→ this means that the receiver only gets signals on the desired channel frequency

CROSS - MODULATION

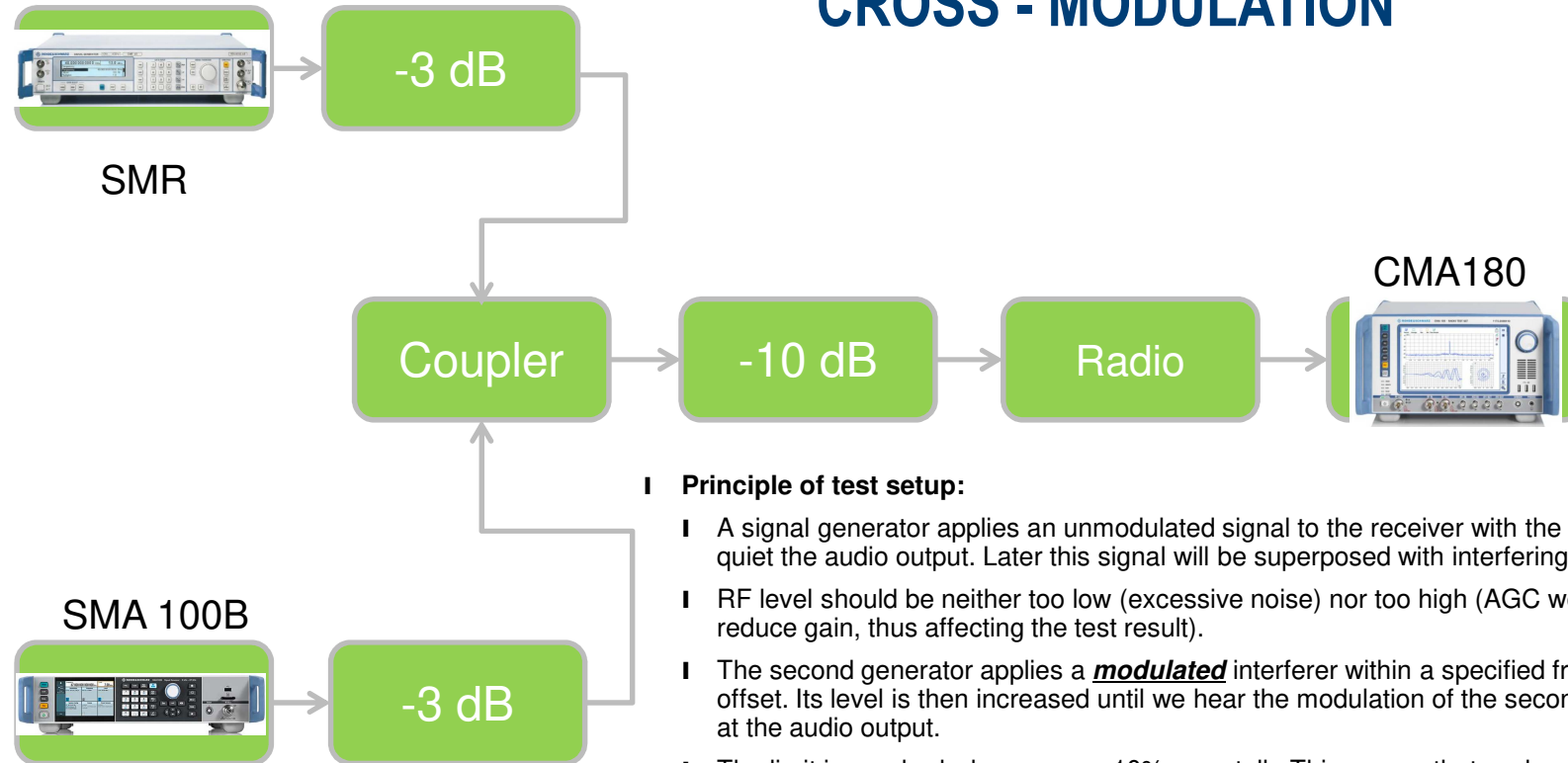

I Principle of test setup:

- I A signal generator applies an unmodulated signal to the receiver with the intention to quiet the audio output. Later this signal will be superposed with interfering signals.
- I RF level should be neither too low (excessive noise) nor too high (AGC would then reduce gain, thus affecting the test result).
- I The second generator applies a **modulated** interferer within a specified frequency offset. Its level is then increased until we hear the modulation of the second generator at the audio output.
- I The limit is reached when we see 10% crosstalk. This means that we hear the audio of the 60% modulated interferer with a level which corresponds to 6% AM modulation for the desired signal.

RECEIVER CONCEPTS

CROSS-MODULATION

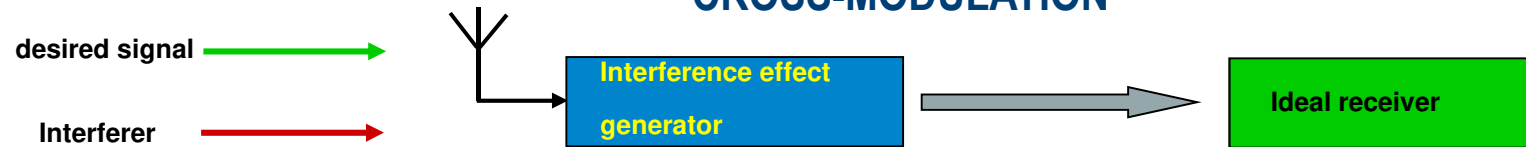

CROSS-MODULATION:

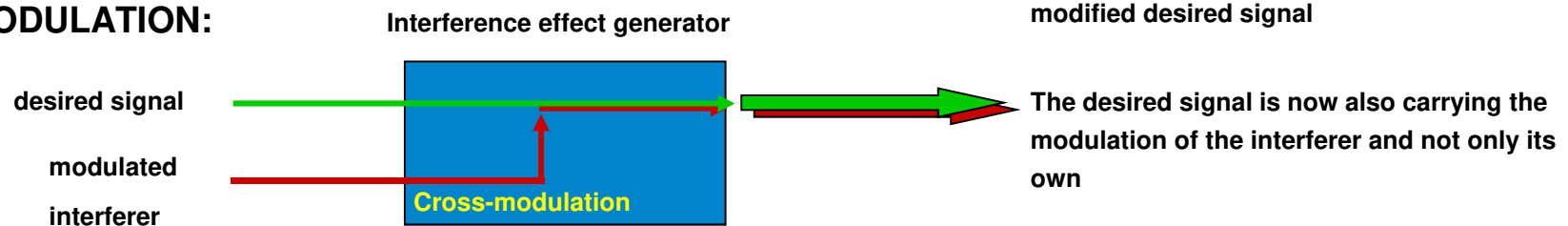

"You can hear the interferer"

- I Saturation effects in amplifiers or other stages in the receiver cause cross-modulation from the interferer to the desired signal.
- I This effect will limit system performance, independent of the strength of the desired signal.
- I One single interferer may be enough to shut down the operation!
- I Improvements can be achieved e.g. by using filters or even attenuators.* *sensitivity penalty!

INTERMODULATION

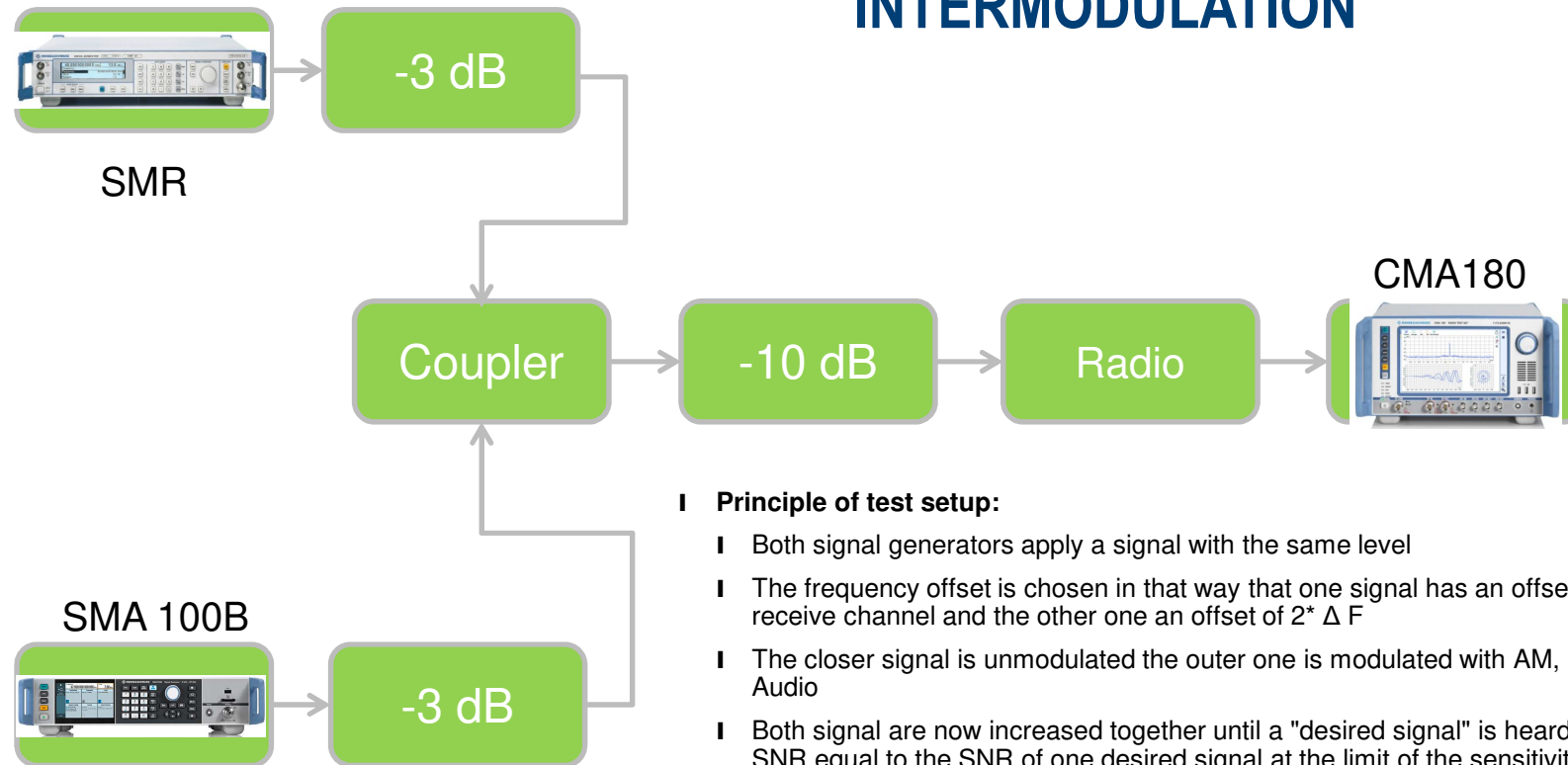

I Principle of test setup:

- I Both signal generators apply a signal with the same level
- I The frequency offset is chosen in that way that one signal has an offset of ΔF to the receive channel and the other one an offset of $2 * \Delta F$
- I The closer signal is unmodulated the outer one is modulated with AM, 30%, 1kHz Audio
- I Both signal are now increased together until a "desired signal" is heard which shows an SNR equal to the SNR of one desired signal at the limit of the sensitivity.
- I Attention: If both signal generators inject significant phase noise into the test setup then the measurements results appears to be too good because the intermodulation product is covered by noise from the signal generators.

RECEIVER CONCEPTS INTERMODULATION

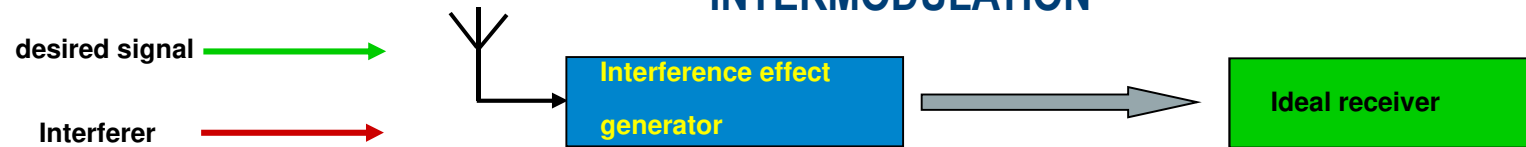

Intermodulation:

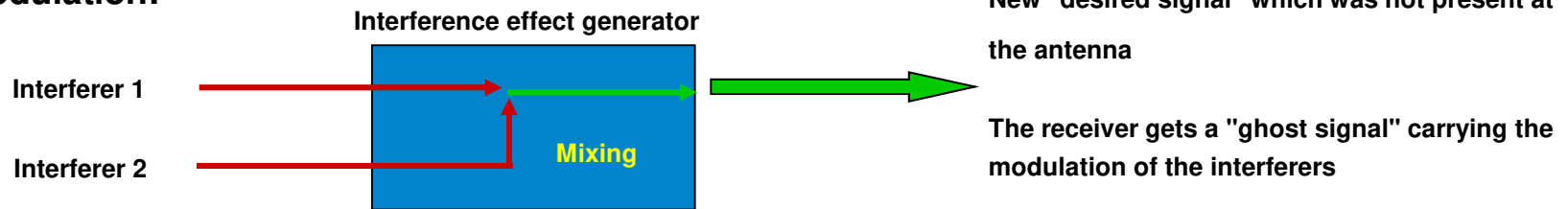

- I Nonlinear effects in amplifiers or other stages in the receiver cause mixing of the interferers. The mixing products are new signals which have not been present at the antenna.
- I The mixing product may fall into the communication channel to which the receiver is tuned if the frequency values match.
- I Improvements can be achieved e.g. by using filters or even attenuators.* **sensitivity penalty!*
- I In addition, interference to working channels can be avoided by frequency planning.

RECEIVER CONCEPTS

INTERMODULATION

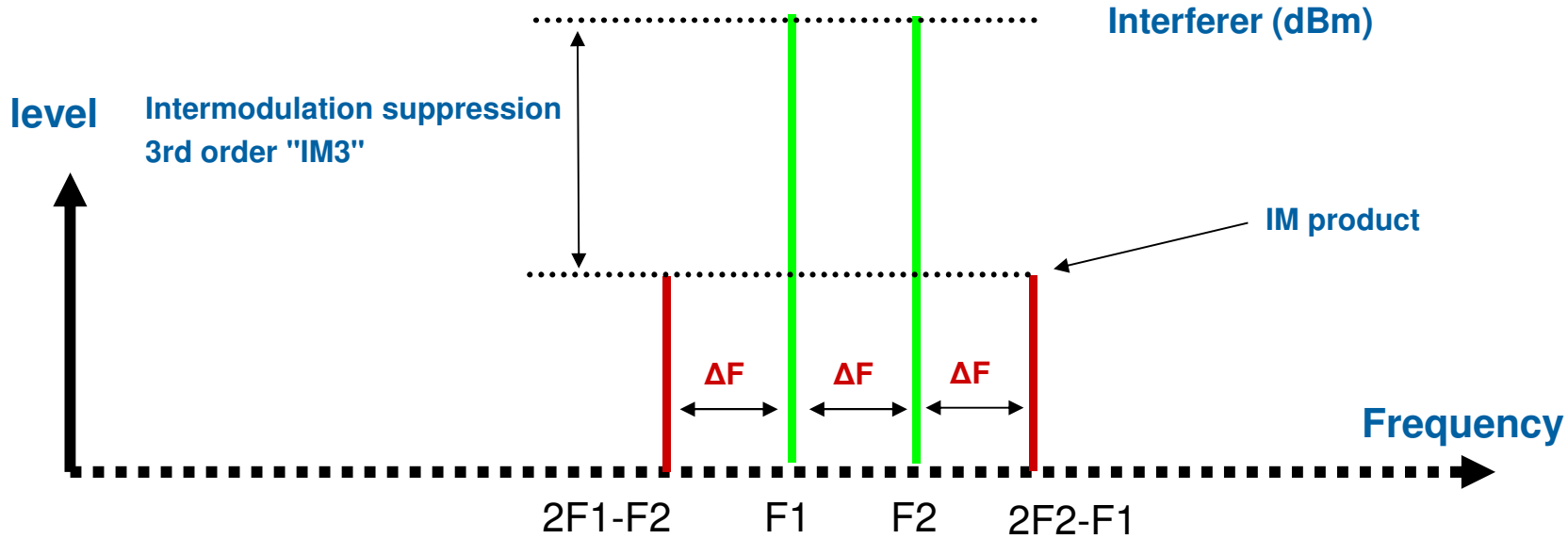

RECEIVER CONCEPTS

INTERMODULATION

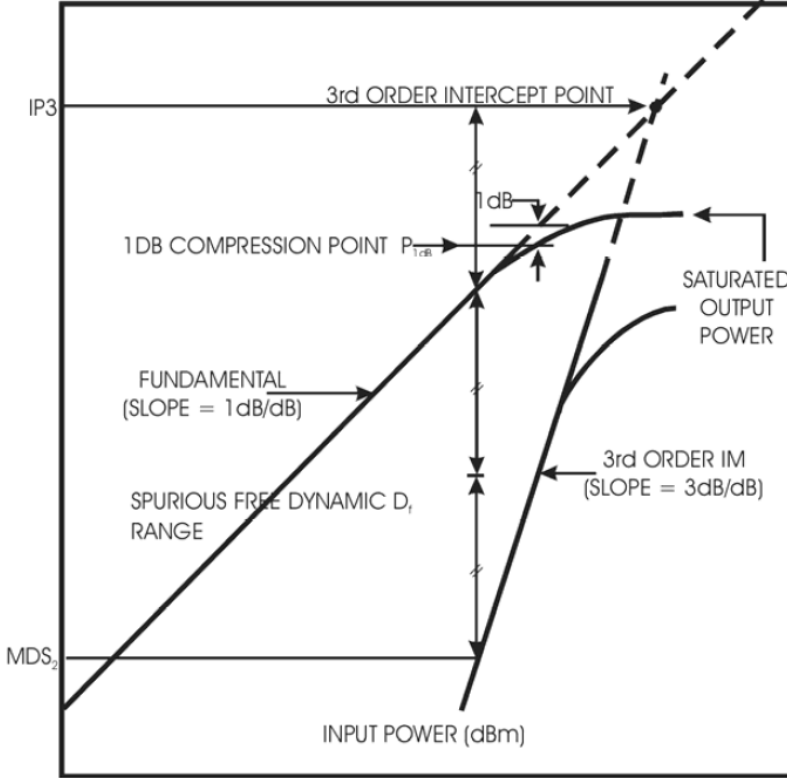

RECEIVER PARAMETERS INTERMODULATION

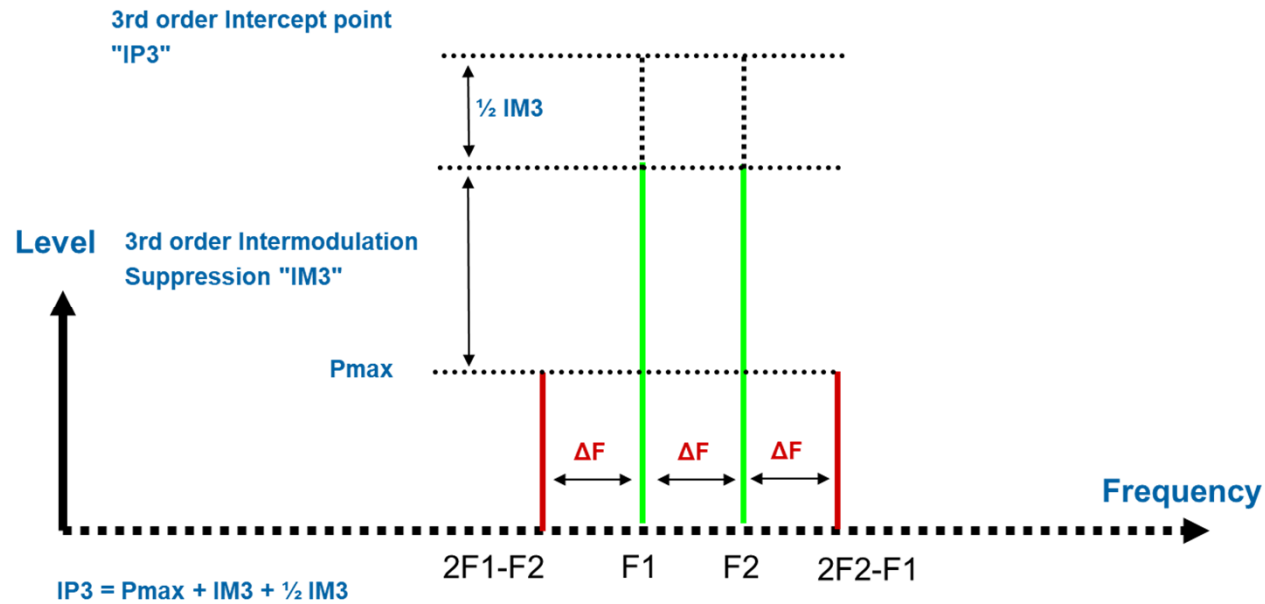

How it works:

A 1dB increase in the level of the interferers results in a 3dB increase for the IM products, IM3 is reduced by 2dB.
If one interferer increases by 1dB, the intermodulation products also rise by approx. 1dB → IM3 unchanged

IFSS

INTERFERENCE FREE SIGNAL STRENGTH

- The 3rd-order IMD (IM3) behavior of an ADC differs completely from that of a conventional RX front end (mixer + LO).
- The IM3 product amplitude varies in a pseudo-random manner with increasing input power, it can be higher or lower at +1dBr than at 0 dBr.
- We propose a new IM3 measurement method: IFSS. The IFSS chart shows IM3 product amplitude vs. 2-tone input power, with the ITU-R P.372 band noise levels for the frequency range and site under test as datum lines.
- The sample chart (next slide) gives the band noise level for Urban, Rural and Quiet Rural P.372 band noise levels at 14 MHz.
- If the IM3 product is below the band noise line, it will not interfere with signals at or above above the band noise line and can thus be disregarded.
- Dithering the ADC renders the curve more monotonic (smoother), at the cost of a ≈ 1 dB increase in receiver's noise floor.

SAMPLE IFSS CHART (14MHZ)

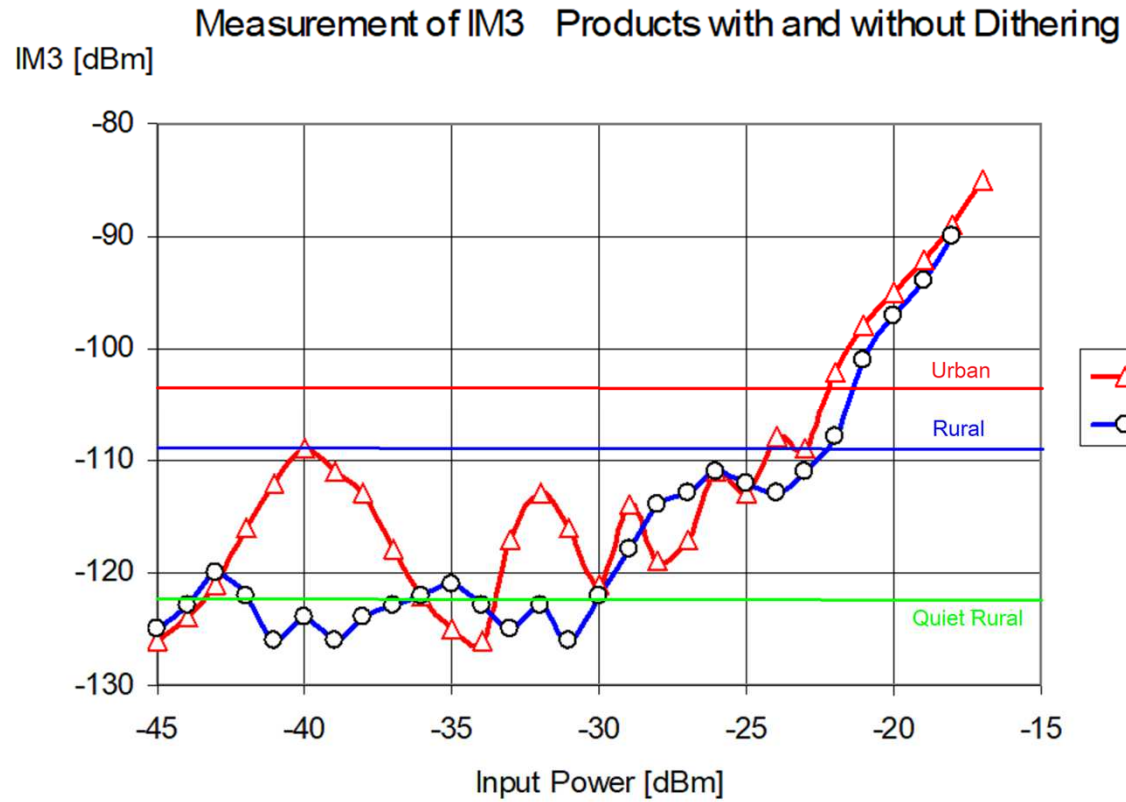

NOISE POWER RATIO (NPR) TESTING

- Originally developed for end-to-end performance testing of analogue FDM (frequency-division multiplex) telecom transmission systems.
- Band-limited Gaussian noise loading is applied to the receiver RF input.
- A deep notch is inserted in the noise band to create a quiet (idle) channel. The notch is slightly wider than the receiver's detection channel.
- The DUT is tuned to centre the detection passband in the notch.
- NPR is the ratio of idle-channel noise power to the noise power in a channel equal in bandwidth to the detection channel, but well outside the idle channel.
- The noise loading emulates many contiguous strong signals, and generates products which appear as noise in the idle channel.
- The higher the NPR, the more resistant the receiver will be to multiple signals.
- Either a noise generator with band-limiting (BPF) and bandstop filters, a vector signal generator (VSG) or an arbitrary waveform generator (AWG) may be used to generate the NPR test waveform.
- An NPR test bench comprising an NPR waveform generator and a spectrum analyzer can be used for NPR stress testing of two-port networks such as RF amplifiers and preselectors, e.g. to detect active and passive IMD.

NPR TESTING OF SUPERHET RECEIVERS

- The noise generator output is set at the optimum noise loading point, where the receiver's audio noise output is 3 dB above noise floor.
- In general, a noise generator with analogue filters will have a deeper notch than an AWG or VSG.
- The noise power P_{TOT} (in dBm at this point is noted.
- NPR is now calculated using the following equation:

$$\mathbf{NPR = P_{TOT} - BWR - MDS} \quad \mathbf{dB} \quad (1)$$

where P_{TOT} = total noise power in dBm in the noise bandwidth B_{RF}

BWR = bandwidth ratio = $10 \log_{10} (B_{RF}/B_{IF})$

B_{RF} = RF bandwidth or noise bandwidth in Hz

(Bandwidth of band-limiting filter)

B_{IF} = receiver IF/detection filter bandwidth in Hz

MDS = minimum discernible signal in dBm (specified at B_{IF})

NPR TESTING OF DIRECT-SAMPLING SDR RECEIVERS

- The theoretical maximum NPR of a “noiseless” ADC can be derived mathematically.
- By normalizing to the ENOB and SNR of a “real-world” ADC, we can calculate our RX ADC’s max. NPR at -1 dBFS.
- Noise loading is applied to the RF input at -1 dBFS, and the NPR read directly off the receiver’s spectrum scope display (if fitted) as notch depth in dB, or calculated using Equation 1 in Slide 67.
- The closer the measured NPR value is to the theoretical value, the better the receiver.

NPR waveform displayed on SDR spectrum scope (example).

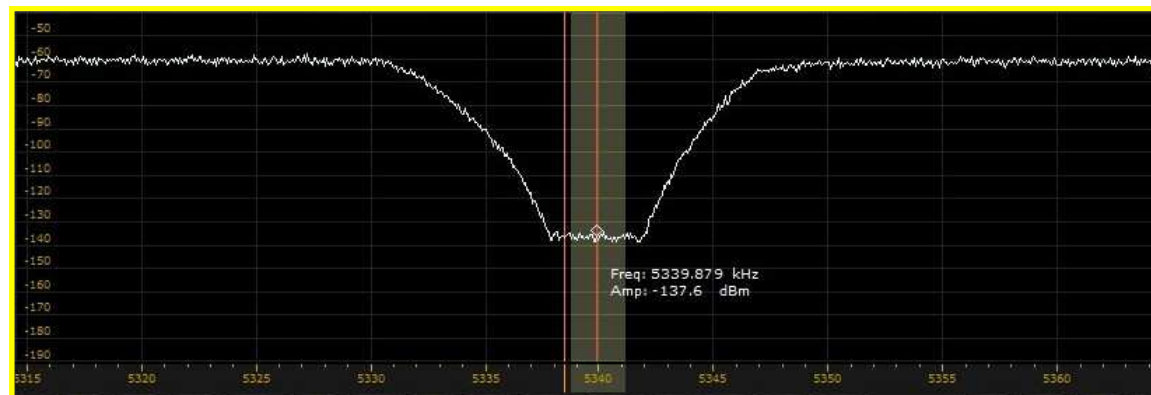

TRANSMITTER PARAMETERS

The main tasks for a transmitter are:

highly efficient radiation of desired signals

and at the same time

protection of all other frequencies outside the working channel

- I **Good transmitters deliver a spectrum which is not wider than required for the chosen modulation scheme**
 - I This is strongly influenced by the structure of the transmitter chain and its filtering – but also by the linearity of the transmitter and by the signal levels used within the transmitter chain.
 - I Outside the modulation spectrum, the noise is caused exclusively by the transmitter chain.

- I **We distinguish between discrete interferers and noise interferers**
 - I Discrete interferers are harmonics and non-harmonic signals
 - I With respect to noise, we distinguish between wideband noise and close-in noise

- I **The measurement of far-out transmitter noise is normally far beyond the dynamic range of standard test equipment e.g. spectrum analyzers.**

TEST EQUIPMENT FOR PHASE NOISE MEASUREMENTS

We look at phase noise in three different areas:

area	Achievable dynamic range for phase noise	Typical frequency offset relative to carrier	Comment
Close in	up to -120dBc/Hz typ.	approx. 20kHz offset	good spectrum analyzer e.g. FSW can operate here without any external devices Typical application: signal generators, communication radios
Medium offset	up to -145dBc/Hz typ.	approx. 1MHz offset	additional tools required around spectrum analyzer Typical application: Local oscillators for receivers, signal generators, communication radios
Far out	up to -200dBc/Hz with good test setup	approx. 10MHz offset or even more	Fairly complex setups may be required to achieve a sufficient dynamic range Fairly critical settings e.g. high levels required; these may destroy a spectrum analyzer front end if settings are not done correctly. Typical application: communication radios for good co-site performance

TEST EQUIPMENT FOR PHASE NOISE MEASUREMENTS

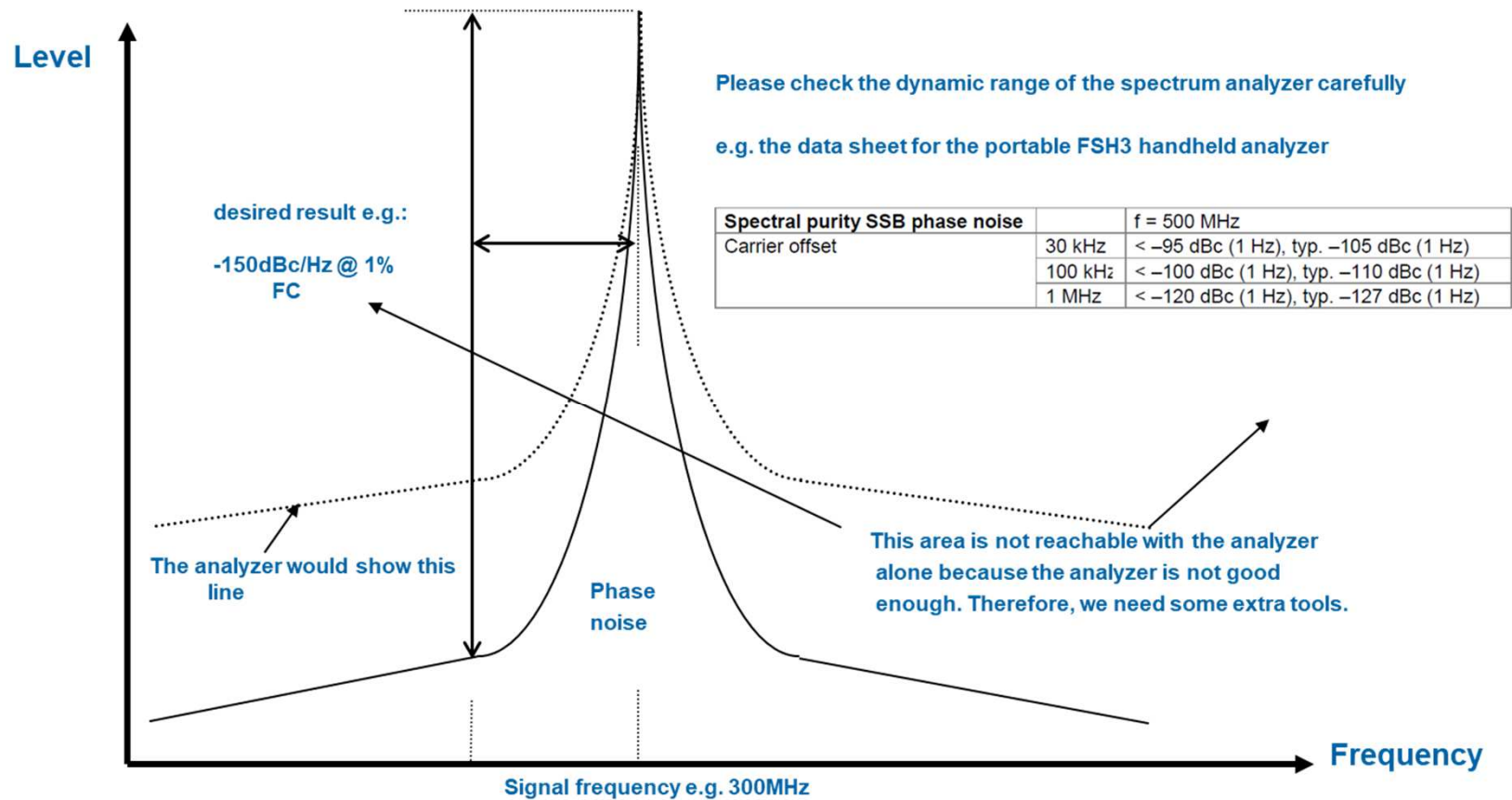

TEST EQUIPMENT FOR PHASE NOISE MEASUREMENTS

Increasing the dynamic range by using a mixer – for medium frequency offsets

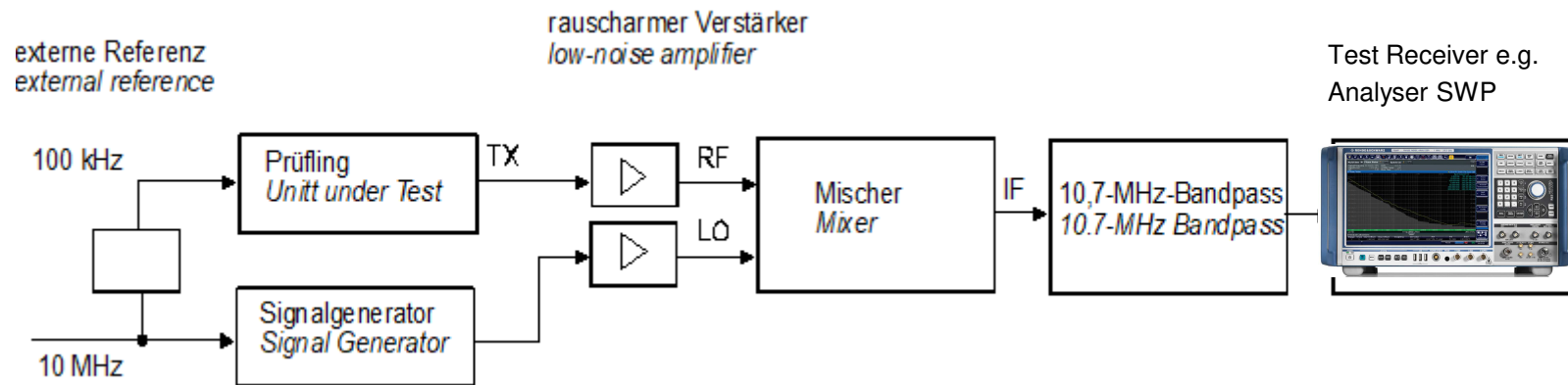

This setup is just an example

TEST EQUIPMENT FOR PHASE NOISE MEASUREMENTS

Increasing the dynamic range by using a 10.7MHz mixer: how it works

1. Measure levels only

Set D.U.T and signal generator to an offset of 10.7 MHz

Measure the level e.g. P0 and record it

Attention: check potential saturation of mixer

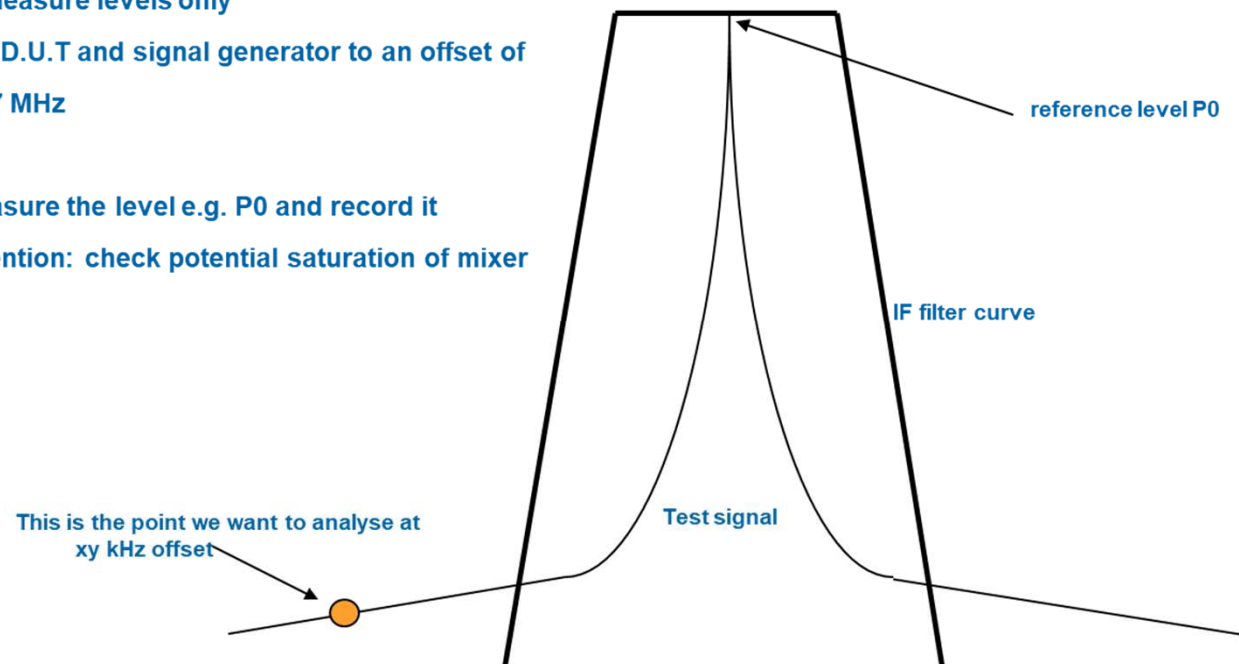

TEST EQUIPMENT FOR PHASE NOISE MEASUREMENTS

Increasing the dynamic range by using a 10.7MHz mixer: how it works

2. Measure the noise power

Set D.U.T and signal generator to an offset of

10.7MHz +/- xy kHz

Adjust sensitivity of analyzer to maximum

Measure noise power and record it e.g. P_n

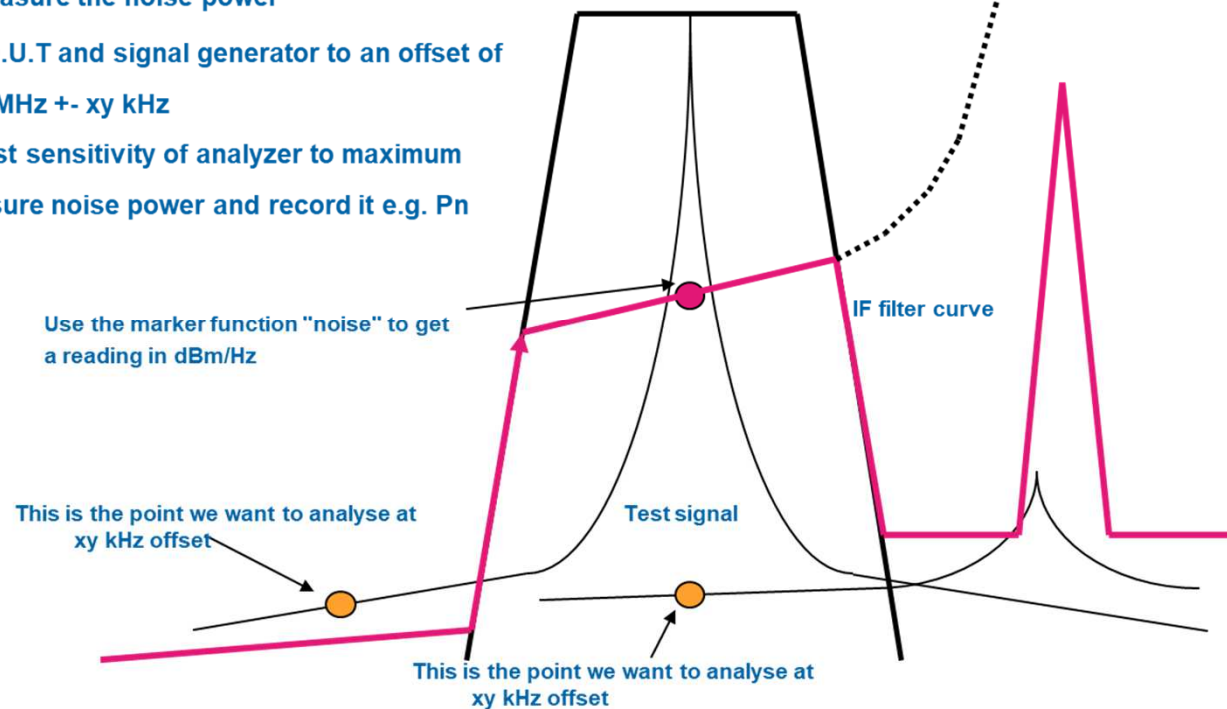

TEST EQUIPMENT FOR PHASE NOISE MEASUREMENTS

Increasing the dynamic range by using a 10.7MHz mixer: how it works

3. Calculate the phase noise value e.g.

Reference level was P0 e.g. - 10dBm

Noise level was Pn e.g. - 145dBm/Hz

Phase noise is therefore: -135dBc/Hz

The dynamic limit for this method is approx. -150dBc/Hz

Attention:

The phase noise of the signal generator may still be significant

Please check all levels carefully. An additional amplifier may be required.

TEST EQUIPMENT FOR PHASE NOISE MEASUREMENTS

Increasing the dynamic range by using a notch filter – for large frequency offsets

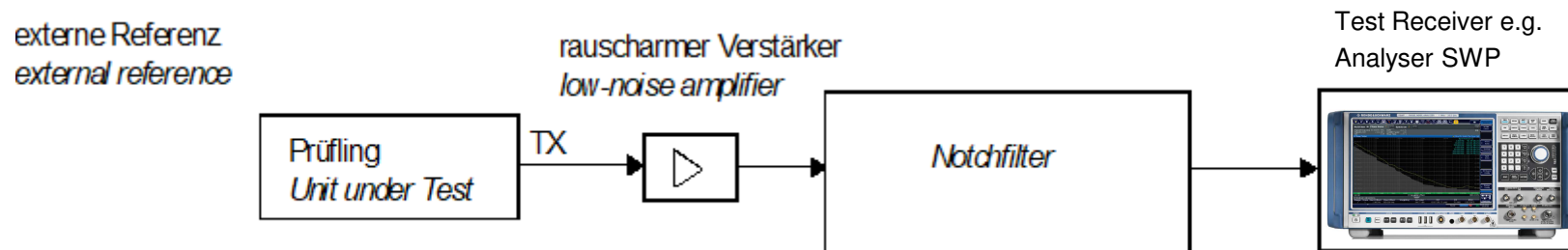

This setup is just an example

TEST EQUIPMENT FOR PHASE NOISE MEASUREMENTS

FAR OUT TRANSMITTER NOISE – A CLOSER LOOK TO IT

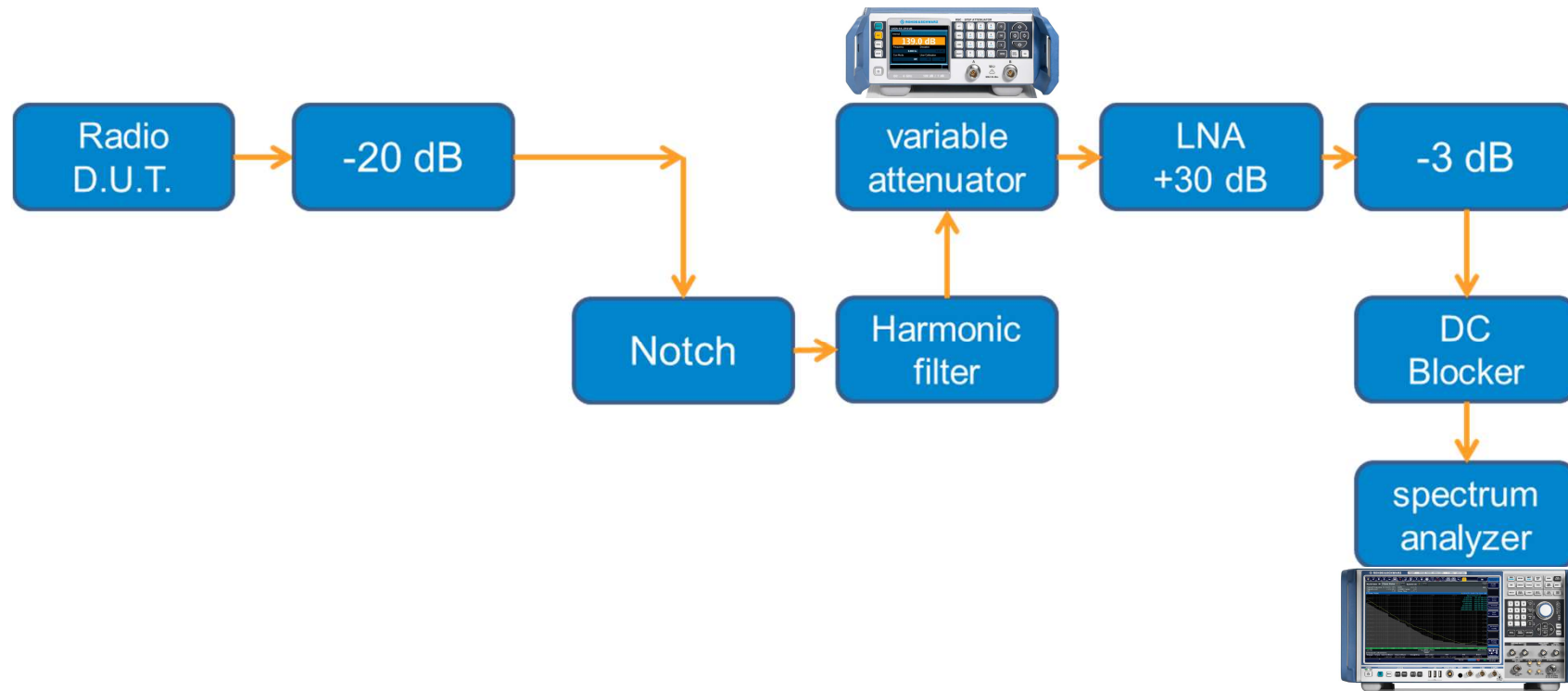

TEST EQUIPMENT FOR PHASE NOISE MEASUREMENTS

Increasing the dynamic range by using a notch filter: how it works

1. Measure levels only

Set notch filter frequency to large offset

Measure level and record it e.g. P0

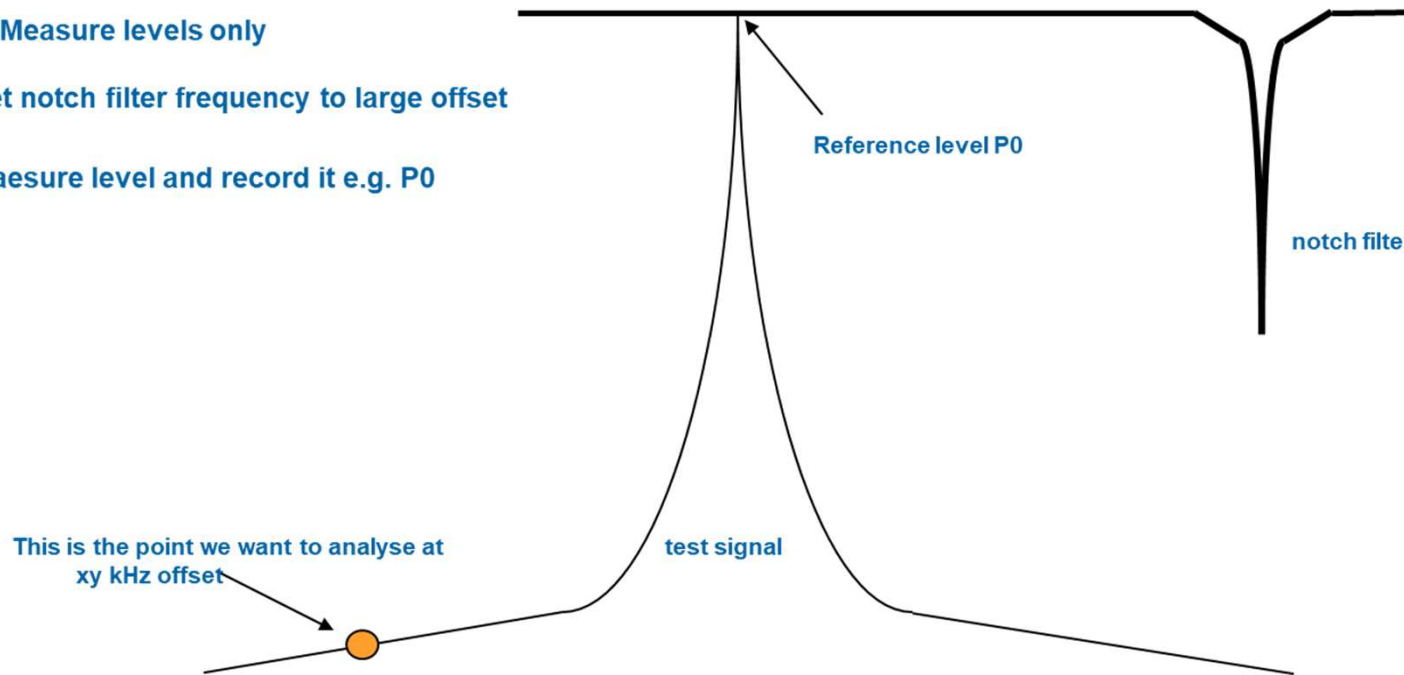

TEST EQUIPMENT FOR PHASE NOISE MEASUREMENTS

Increasing the dynamic range by using a notch filter: how it works

2. Measure the noise power

Tune notch filter to the test frequency

Adjust sensitivity of analyzer to maximum

Measure noise power and record it e.g. Pn

Use marker function "Noise" → (dBm(Hz))

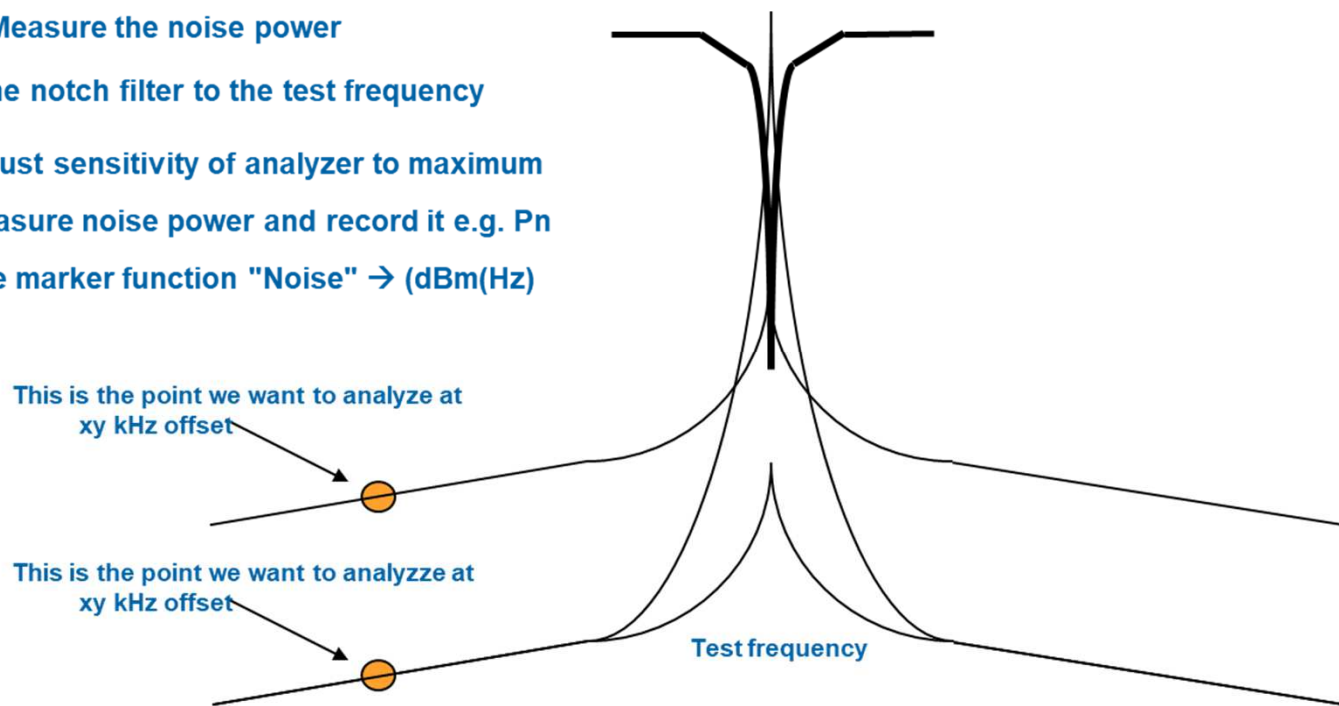

TEST EQUIPMENT FOR PHASE NOISE MEASUREMENTS

Increasing the dynamic range by using a notch filter: how it works

3. Calculate the phase noise value e.g.

Reference level was P_0 e.g. + 15dBm

Noise level was P_n e.g. - 140dBm/Hz

Phase noise is therefore - 155dBc/Hz-

The dynamic limit for this method is approx. -200dBc/Hz

Attention:

The phase noise of the signal generator may still be significant.

Please check all levels carefully. An additional amplifier may be required.

TEST EQUIPMENT FOR PHASE NOISE MEASUREMENTS

Increasing the dynamic range by using a notch filter: an example

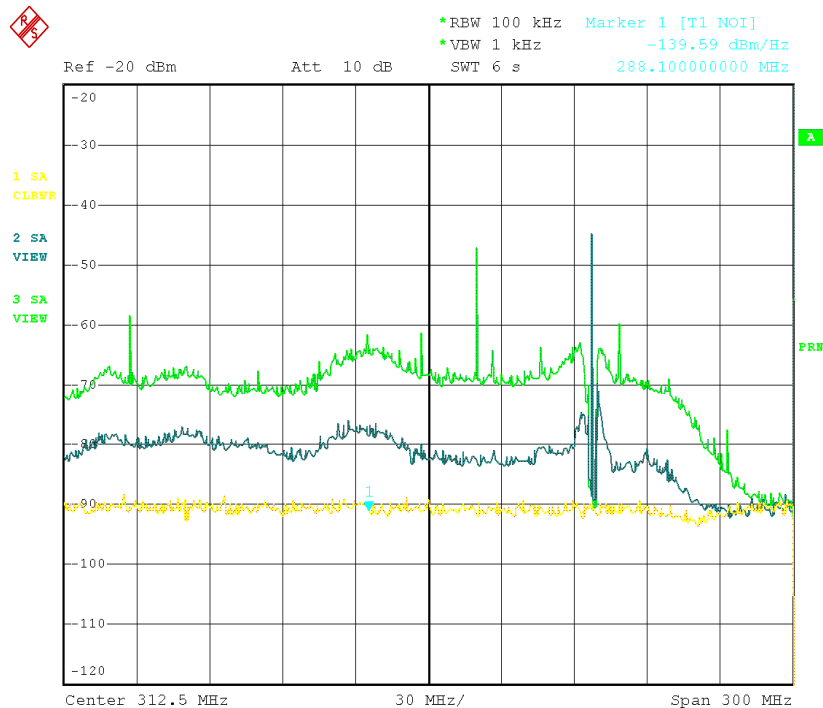

The carrier is suppressed by the notch filter and the spectrum remaining after the notch is then amplified again.

With this setting, the carrier would be

- theoretically - at +53dBm.

- 140dBm/Hz corresponds to -193dBc/Hz.

Date: 20.NOV.2003 14:35:20

TEST EQUIPMENT FOR FINDING UNDESIRE EMISSIONS

An example for measurement with typical -80dBc dynamic range

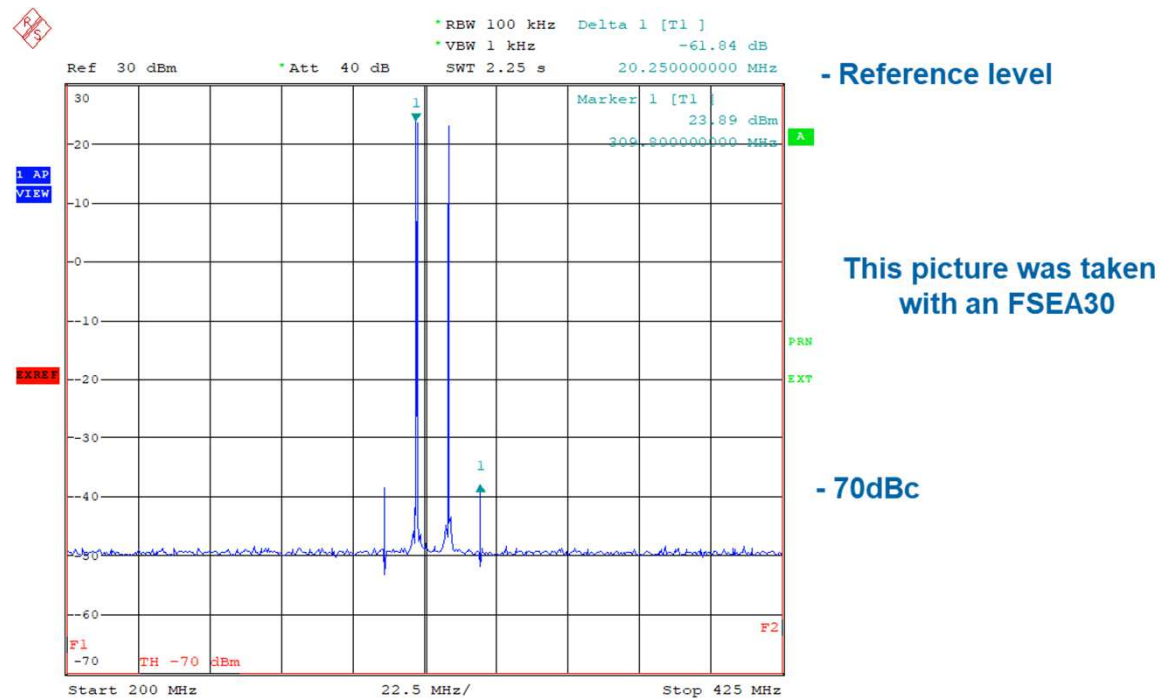

TEST EQUIPMENT FOR FINDING UNDESIRE EMISSIONS

An example for measurement with typical - 140dBc dynamic range

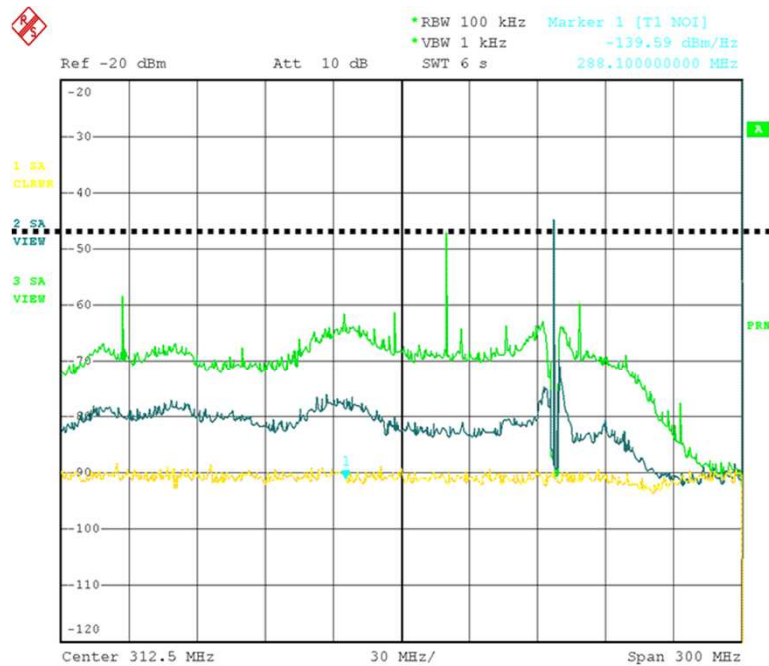

The carrier is suppressed by the notch filter and the remaining spectrum behind the notch is then amplified again

With this setting at +53dBm, the carrier would be - theoretically – at -100dBc

-100dBc !!

Date: 20.NOV.2003 14:35:20

TEST EQUIPMENT FOR FINDING UNDESIRE EMISSIONS

An example for measurements to identify harmonics

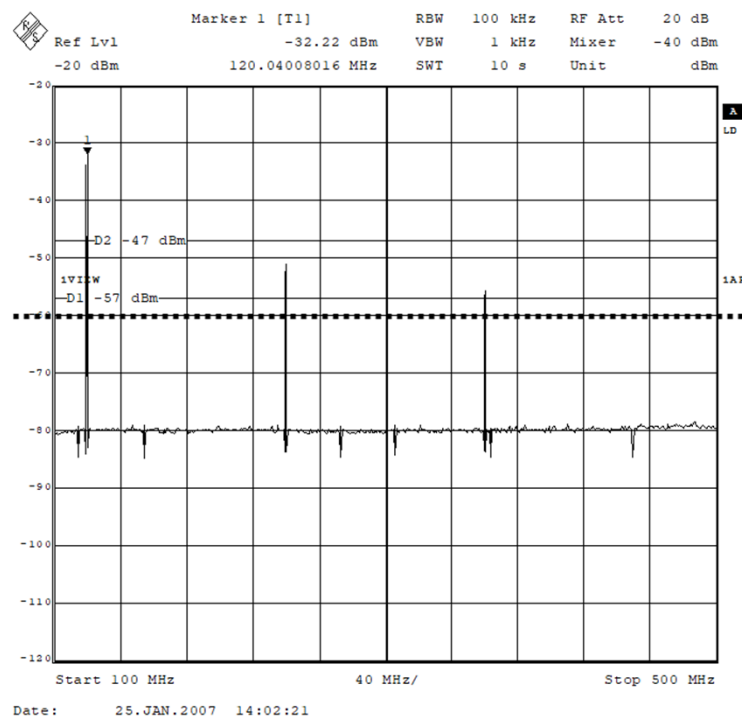

The carrier (+40dBm!) is reduced by the notch filter

Attention: Do not detune the notch now,
otherwise the analyzer may be damaged.

-100dBc !!

TRANSMITTER PARAMETERS

CARRIER POWER

- I **Single carrier signals which are only phase- and/or frequency-modulated show a constant output power which is equal to the carrier power (constant envelope signals).**
- I **For single carrier signals which are additionally varying in amplitude, the instantaneous transmit power is higher than the unmodulated carrier power.**
 - I The expression "carrier power" applies only to the unmodulated signal.
 - I The carrier power for a modulated signal is equal to the spectrum line in the center of the spectrum (see also AM-spectrum).
 - The spectral lines additional to the carrier line represent the increase of power when the signal is modulated.
- I **For multi-carrier signals, the expression "carrier power" does not apply.**
 - I For these types of signals, we have to specify the transmitted power differently, e.g. peak power, effective power etc.

MEASURING TRANSMITTER POWER A TRADITIONAL TEST SETUP

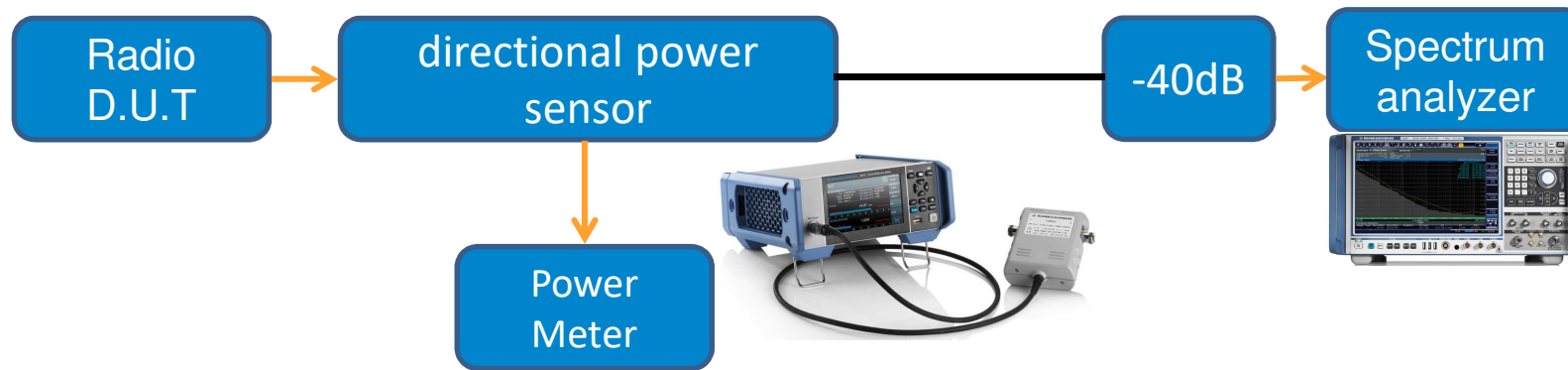

I How it works:

- I The directional power sensor detects the forward power which is transmitted to the load e.g. antenna
- I We use a 50Ω termination as load.
- I With a spectrum analyzer we check the transmitter for correct operation, e.g. no instability etc.
- I With unmodulated signals we clearly know what we measure → the carrier power
- I With modulated signals we must know how the power meter reacts

TRANSMITTER PARAMETERS

CARRIER POWER

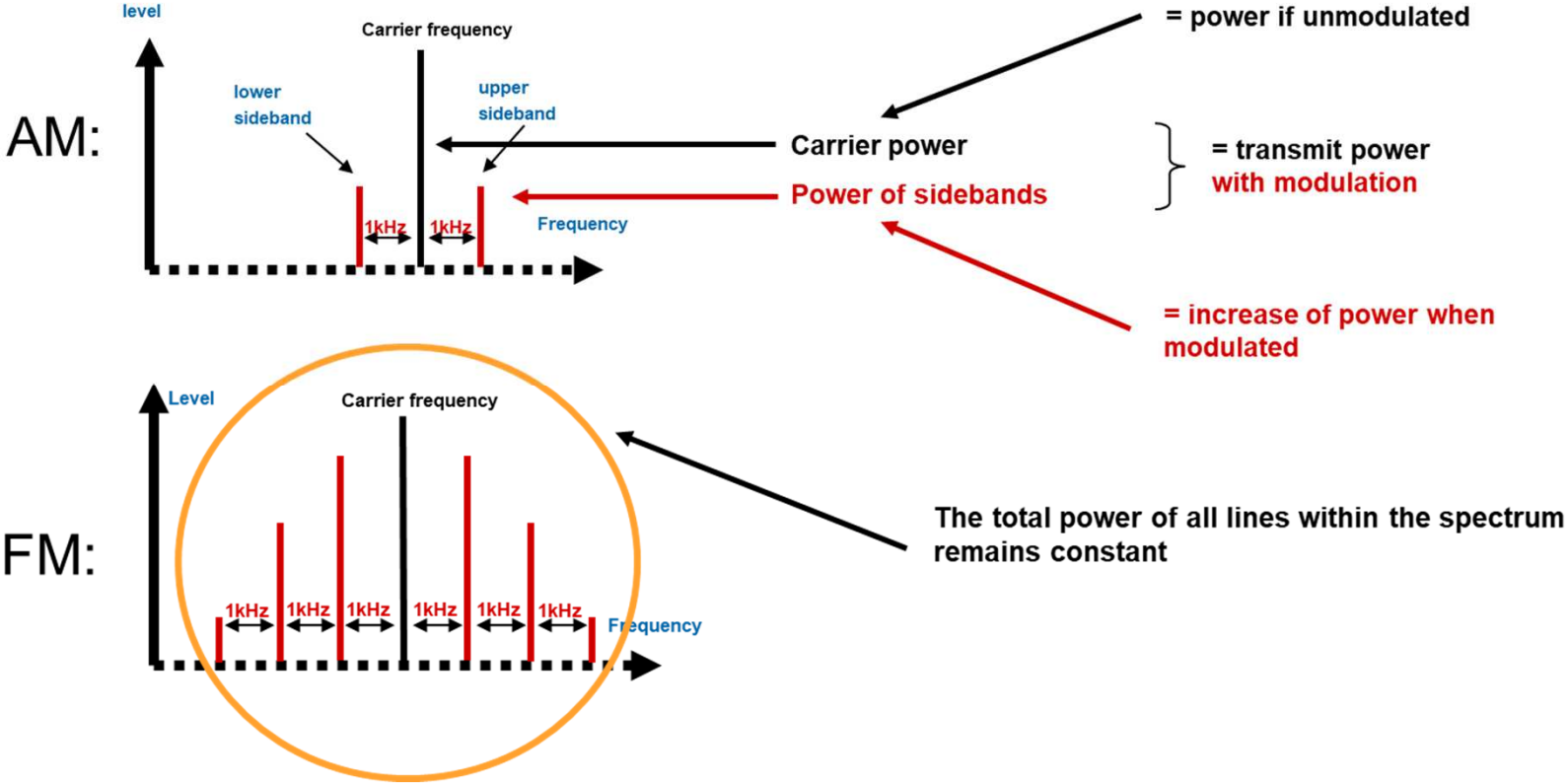

TRANSMITTER PARAMETERS

PEAK POWER – EFFECTIVE (AVERAGE) POWER – PAPR – CREST FACTOR

Envelope of a complex signal with the following parameters: QPSK, Root raised cosine filter with $\alpha = 0.2$

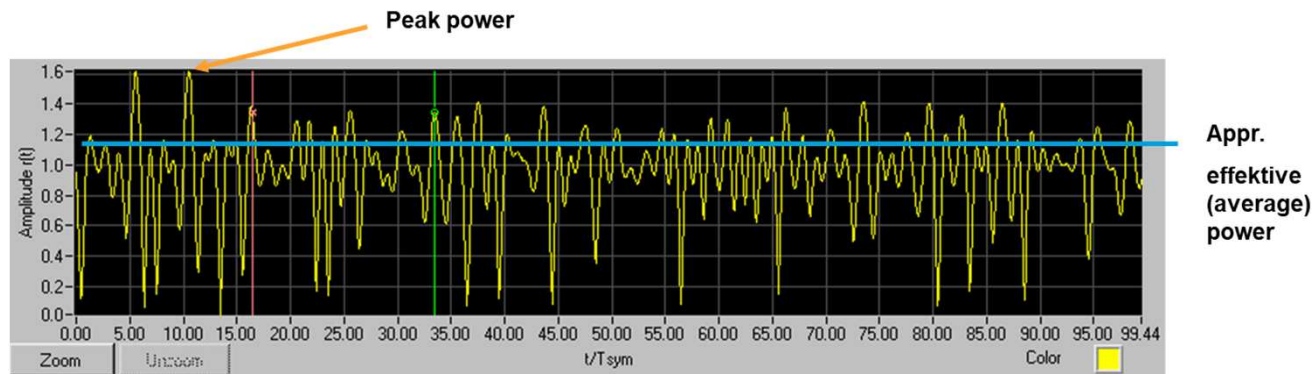

- I "Peak Power" = the highest power level which appears within a given time window, also called "PEP" (peak envelope power)
- I "Average Power" = the effective power level appearing within a given time window which would heat up a dummy load (for example)
- I Crest Factor "P/AR" = **P** – to – **A**verage – **R**atio → the relationship of peak power to effective power of a signal

Within a transmitter module, the power transistors are chosen based on PEAK power while the heat sink is chosen based on average power and efficiency.

TRANSMITTER PARAMETERS

VSWR – IDEAL MATCH - MISMATCH

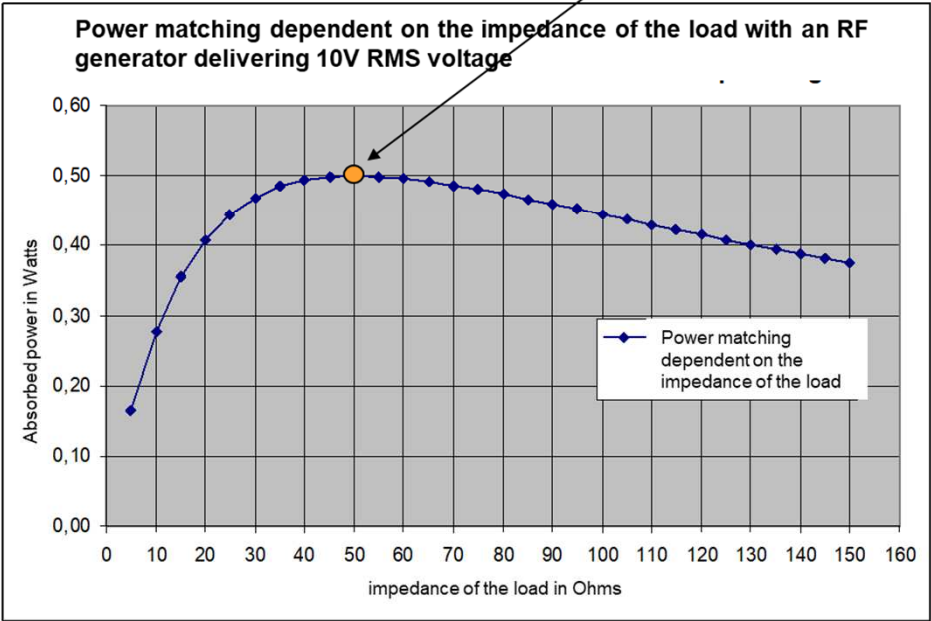
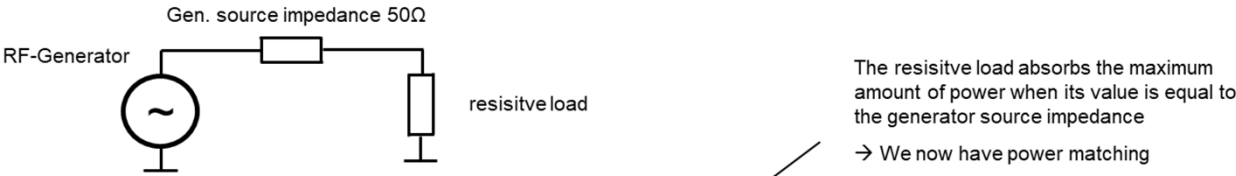

TRANSMITTER PARAMETERS

VSWR – IDEAL MATCH - MISMATCH

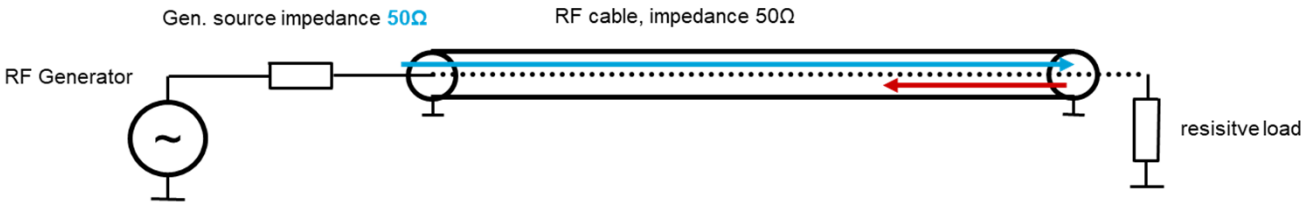

An RF cable with an impedance of 50Ω accepts the same amount of power at the input as an ideal 50Ω resistor and forwards this power to the output.

→ Forward wave or power

If the termination at the output of the cable is not equal to the impedance, then the load resistor is unable to absorb all the power. The "unusable" power is reflected and travels back to the input end of the cable.

→ reflected wave or power

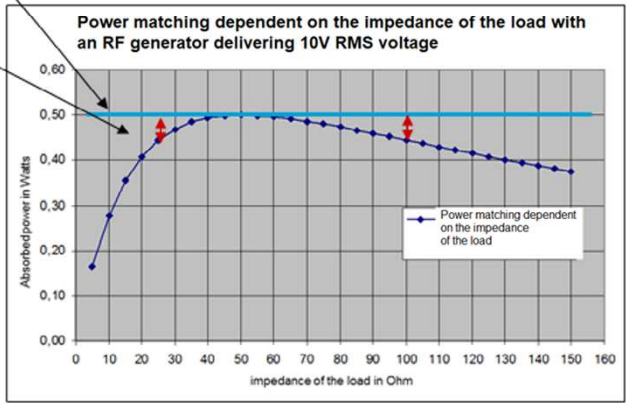

TRANSMITTER PARAMETERS

VSWR – IDEAL MATCH - MISMATCH

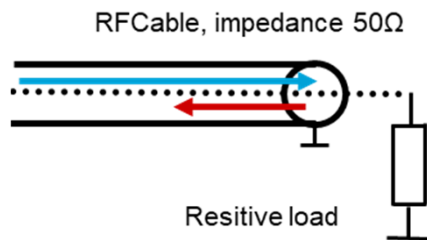

- I Forward and reflected waves are superposed.
 - I The result is a "standing wave" on the cable. If you take a power sensor and sense the power along the cable you will find areas with high levels and those with low levels repeated every half wavelength.
 - I VSWR = Voltage Standing Wave Ratio is characterizing the strength of the standing wave.
 - I A good match means source impedance = load impedance → VSWR = 1 : 1
 - I A bad match means source impedance ≠ load impedance :
- $VSWR = N : 1 \ (1 \ll N < \infty)$
- I VSWR 2:1 means that the source impedance is double or half the impedance of the load

TRANSMITTER PARAMETERS

VSWR – IDEAL MATCH - MISMATCH

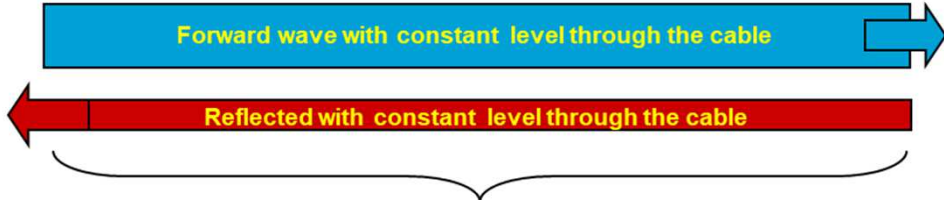
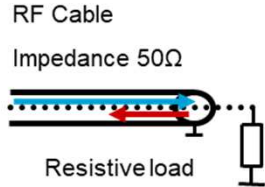

The superposition leads to a fixed standing wave with an unequal distribution of level along the cable

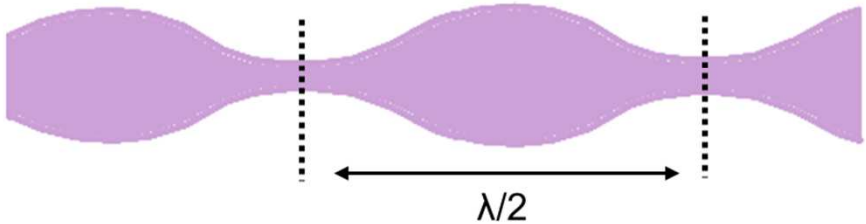

The positions of maximum and minimum amplitudes repeat after every half wavelength

The minima and maxima, including their positions relative to the end of the cable, allow us to calculate the complex impedance of the load at the end of the cable → This is what network analyzers do.

TRANSMITTER PARAMETERS

VSWR – IDEAL MATCH - MISMATCH

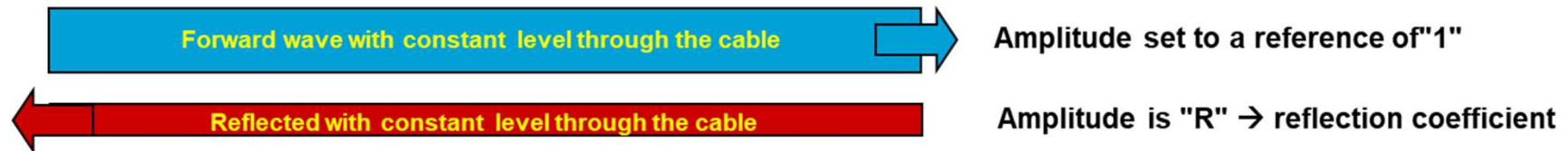

The VSWR value can be calculated as follows: $VSWR = (1+R)/(1-R)$ example: $R=0.5$ leads to VSWR 3 : 1

Some practical hints:

- I We often use the term "return loss" . This is the ratio of forward power to reflected power in dB.
 - I Example: $R = 0.5 \rightarrow$ reflected power is 25% of the forward power \rightarrow return loss is therefore 6dB.
- I The dominant load impedance for a transmitter is the antenna.
- I UHF communication radios must be able to operate at VSWR 2 : 1 or higher without any problems.
- I Radios for the tactical VHF band (30 – 88MHz) must operate with a VSWR of at least 3 : 1.
- I An antenna with a VSWR of 3 : 1 still radiates 75% of the input power.
- I Higher VSWR may lead to a reduction of output power, but must not damage or destroy any equipment.
- I The attenuation of RF cables "improves" the VSWR because forward and reflected power are reduced.

TRANSMITTER PARAMETERS

MEASURING TRANSMIT POWER WITH MISMATCH CONDITIONS

- I A transmitter must operate even with high VSWR. This must be demonstrated quite often.
- I This test case requires us to apply any defined VSWR to the transmitter while measuring the output power at the same time.
- I The VSWR must be variable, including its phase.

Transmitter data

Unless stated otherwise, specs refer to the antenna terminal and involve an antenna impedance of 50 Ω (max. VSWR = 1.1), nominal output power and nominal power supply.

Output power		
AM carrier power		30 W nominal, 1 W to 30 W adjustable
FM/FSK		100 W nominal, 1 W to 100 W adjustable
Power setting		quasi-continuously and independently for AM and FM
Power reduction	VSWR ≤ 2	≤ 1 dB
	VSWR > 2	graceful degradation
	26 V (FM)/28 V (AM) to 19 V DC	graceful degradation from nominal power
Permissible mismatch without damage		short circuit to open circuit, all phases

TRANSMITTER PARAMETERS

MEASURING POWER WITH VSWR

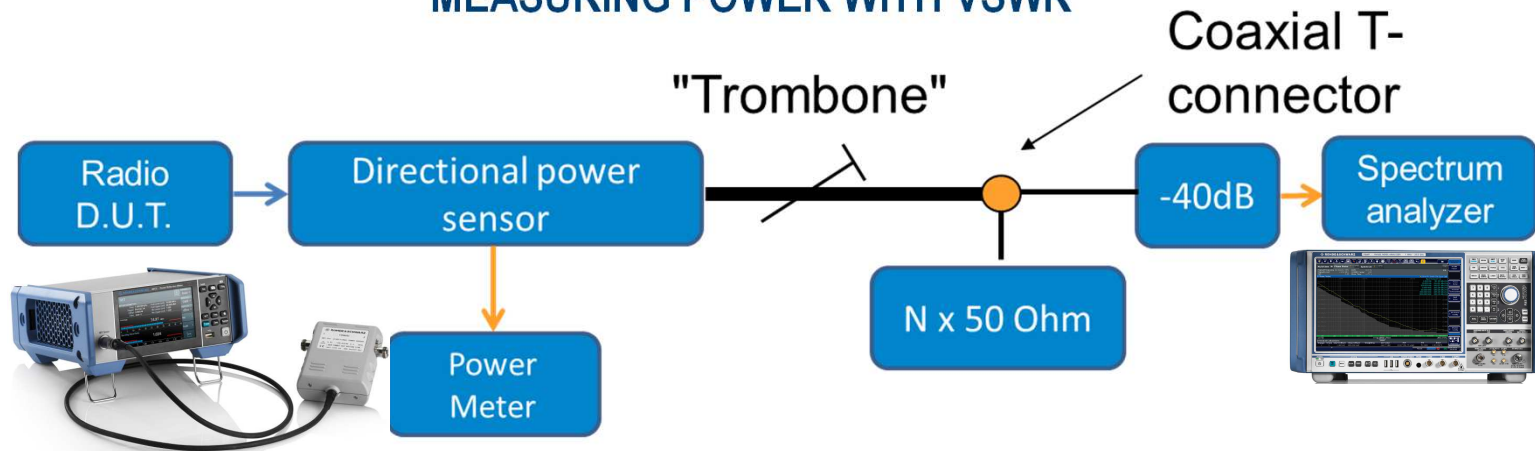

I How it works:

- I With a T-Connector several (N) 50Ω loads are connected to the cable to achieve a defined VSWR at this position
- I For $N = 1$ the $VSWR = 2$, in general $VSWR = N+1$
- I With an RF cable of variable length (using a Trombone section), any phase angle can be set
- I The small attenuation values of all cables in this setup lead to a VSWR value at the output of the transmitter which is slightly better than that adjusted at the T-Connector.
- I In cases where a more precise VSWR value is required, the test setup can be modified e.g. by adding a bandpass filter.

TRANSMITTER PARAMETERS

MEASURING POWER WITH PRECISELY SET VSWR

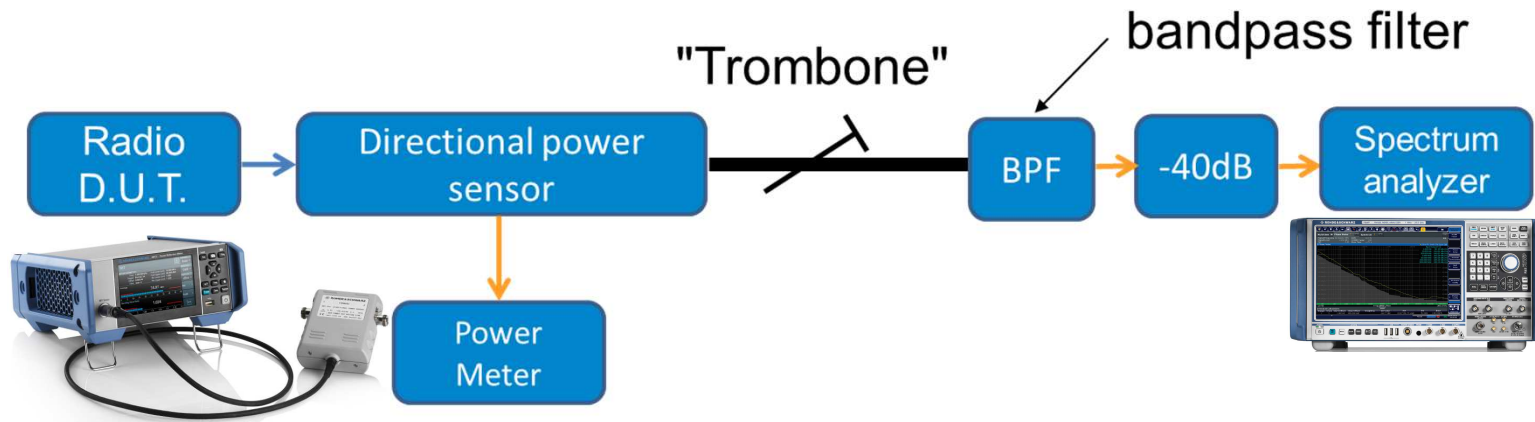

I How it works:

- I By detuning the bandpass filter any VSWR value can be obtained.
- I With an RF cable of variable length (using a Trombone section), any phase angle can be set
- I The precision of this test setup depends only on the precision of the directional power sensor.

A LOOK AT PRACTICAL INSTALLATIONS

SOME TYPICAL ANTENNA CONFIGURATIONS

- I Antennas are the most important parts of a radio-communication system.
- I Good antennas at good locations are mandatory for high performance in the operation of a radio-communication system.
- I Antennas transform electromagnetic signals in the air into electrical signals for the radio and vice versa.
- I The size and the performance of antennas is closely related to the wavelengths in use.
- I It is a real challenge to develop antennas with small dimensions relative to the wavelength, while also covering a wide frequency range.



A LOOK AT PRACTICAL INSTALLATIONS

SOME TYPICAL ANTENNA CONFIGURATIONS

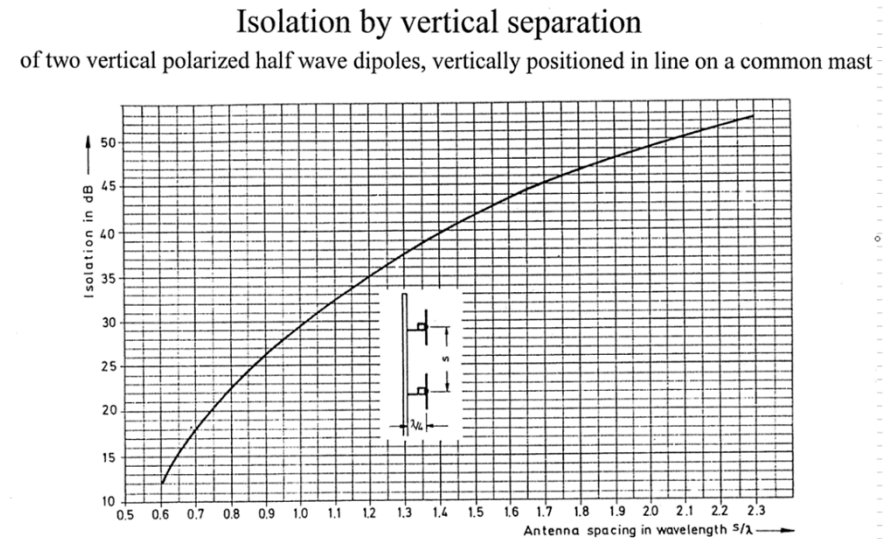
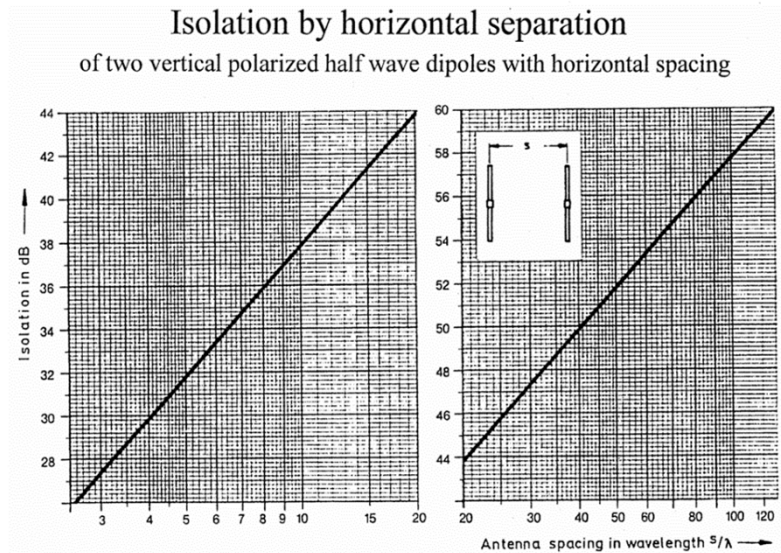

- I It is often the case that we need a minimum value of antenna isolation, but we do not have sufficient space within the installation to achieve the required separation.
- I In such cases, we use filters to enhance signal isolation.

A LOOK AT PRACTICAL INSTALLATIONS

SOME TYPICAL ANTENNA CONFIGURATIONS

$\lambda/4$ - Antenne auf leitender Ebene		3,28; (5,1 dB)	$0,261\lambda^2$	$\frac{\lambda}{2\pi} = 0,15\lambda$	40Ω		
kurzer Dipol $l \ll \lambda$		1,5; (1,9 dB)	$\frac{3\lambda^2}{8\pi} = 0,12\lambda^2$	$\frac{l}{\lambda}$	$20 \left(\frac{\pi l}{\lambda}\right)^2 \Omega$		
$\lambda/2$ - Dipol		1,64; (2,1 dB)	$0,13\lambda^2$	$\frac{\lambda}{\pi} = 0,32\lambda$	73Ω		
λ - Dipol		2,41; (3,8 dB)	$0,19\lambda^2$	$\gg \lambda$	209Ω		
$\lambda/2$ - Schleitendipol		1,64; (2,1 dB)	$0,13\lambda^2$	$\frac{2\lambda}{\pi} = 0,64\lambda$	290Ω		
Schlitzeantenne in Halbraum strahlend		3,28; (5,1 dB)	$0,26\lambda^2$	-	$\approx 500\Omega$		
kleiner Rahmen, n - Windungen, beliebige Form		1,5; (1,9 dB)	$\frac{3\lambda^2}{8\pi} = 0,12\lambda^2$	$\frac{2\pi n A}{\lambda}$	$\frac{3100 n^2 (A/m)^2}{(\lambda/m)^4}$		
Spulenantenne auf langen Ferritstab $l \gg D$		1,5; (1,9 dB)	$\frac{3\lambda^2}{8\pi} = 0,12\lambda^2$	$\frac{\pi^2 n \mu_r D^2}{2\lambda}$	$19100 n^2 \mu_r^2 \left(\frac{D}{\lambda}\right)^4$		
Linie aus Hertzischen Dipolen $l \gg \lambda$		$\approx \frac{4}{3} \frac{l}{\lambda}$	$\frac{l\lambda}{6} = 0,17l\lambda$	-	-		
Zeile aus Hertzischen Dipolen $l \gg \lambda$		$\approx \frac{8}{3} \frac{l}{\lambda}$	$\frac{l\lambda}{4} = 0,25l\lambda$	-	-		
einseitig strahlende Fläche $a \gg \lambda, b \gg \lambda$		$\approx 6,5 \cdot 10^6 \lambda^2$ dB	0 dB	-	-		
Yagi-Uda-Antenne mit 4 Direktoren		$\approx 10; (10 dB)$	-	-	-		



A LOOK AT PRACTICAL INSTALLATIONS

SIMULTANEOUS OPERATION - CO-SITE

- I The user expects:
 - I → Transmission with one feedline
 - I and at the same time
 - I → Reception of weak signals with all remaining feedlines
 - I without a significant reduction of sensitivity
 - I also at the same time – with low isolation between antennas and also with low frequency offsets.

Typical values are:

- | | | |
|--------------------|-------------------------|--------------------------|
| I Vehicular: | Frequency offset 5-10%, | Antenna isolation > 10dB |
| I Stationary/Ship: | Frequency offset 1-2%, | Antenna isolation > 30dB |
| I Airborne: | Frequency offset 1-2%, | Antenna isolation > 50dB |

A LOOK AT PRACTICAL INSTALLATIONS

SIMULTANEOUS OPERATION - CO-SITE

The most critical RF parameters are:

I In RX Mode:

- I Desensitization
- I Spurious reception
- I Nonlinearities

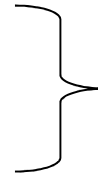

Immunity against strong interferers

I In TX Mode:

- I Noise
- I Discrete Spurs



Protection for other systems

I Optimizing the **total** system performance

OPTIMIZATION GOALS FOR A SYSTEM LAYOUT

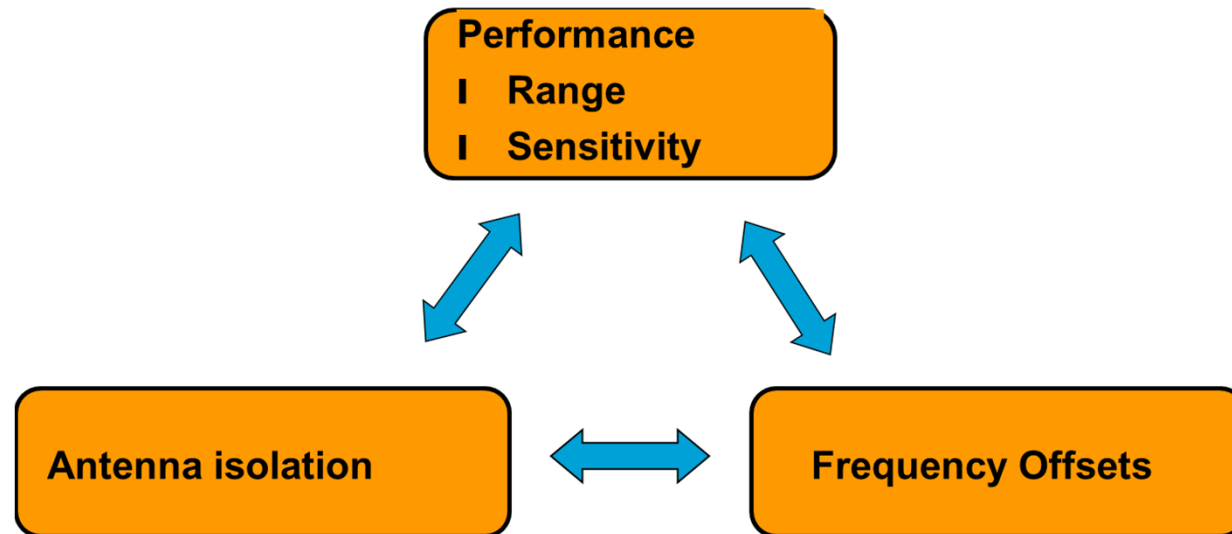

Goal: Optimizing the entire system!

The two extremes:

→ An excellent single box may be nice, but may not work within a system

→ A standard box may work excellently in a well designed system environment

EVALUATION OF CRITICAL HF SYSTEM PARAMETERS

→ CO-SITE

This is a proven way to proceed:

- I Co-siting of a practical transmitter (TX) with an ideal receiver (RX) → TX Noise
- I Co-siting of a practical receiver (RX) with an ideal transmitter (TX) → Desensitization
- I Co-siting of a practical receiver (RX) with a practical transmitter (TX)

→ With this proven conceptual analysis, it is possible to evaluate the most critical RF parameters of any RF communication system.

Please proceed in this order:

- I TX Noise + RX noise figure
- I RX Desensitization
- I Cross-modulation
- I Nonlinearities
- I Others e.g. discrete spurs, TX backward intermodulation - and many more!

CO-SITE MECHANISMS – TRANSMITTER NOISE SPECTRUM

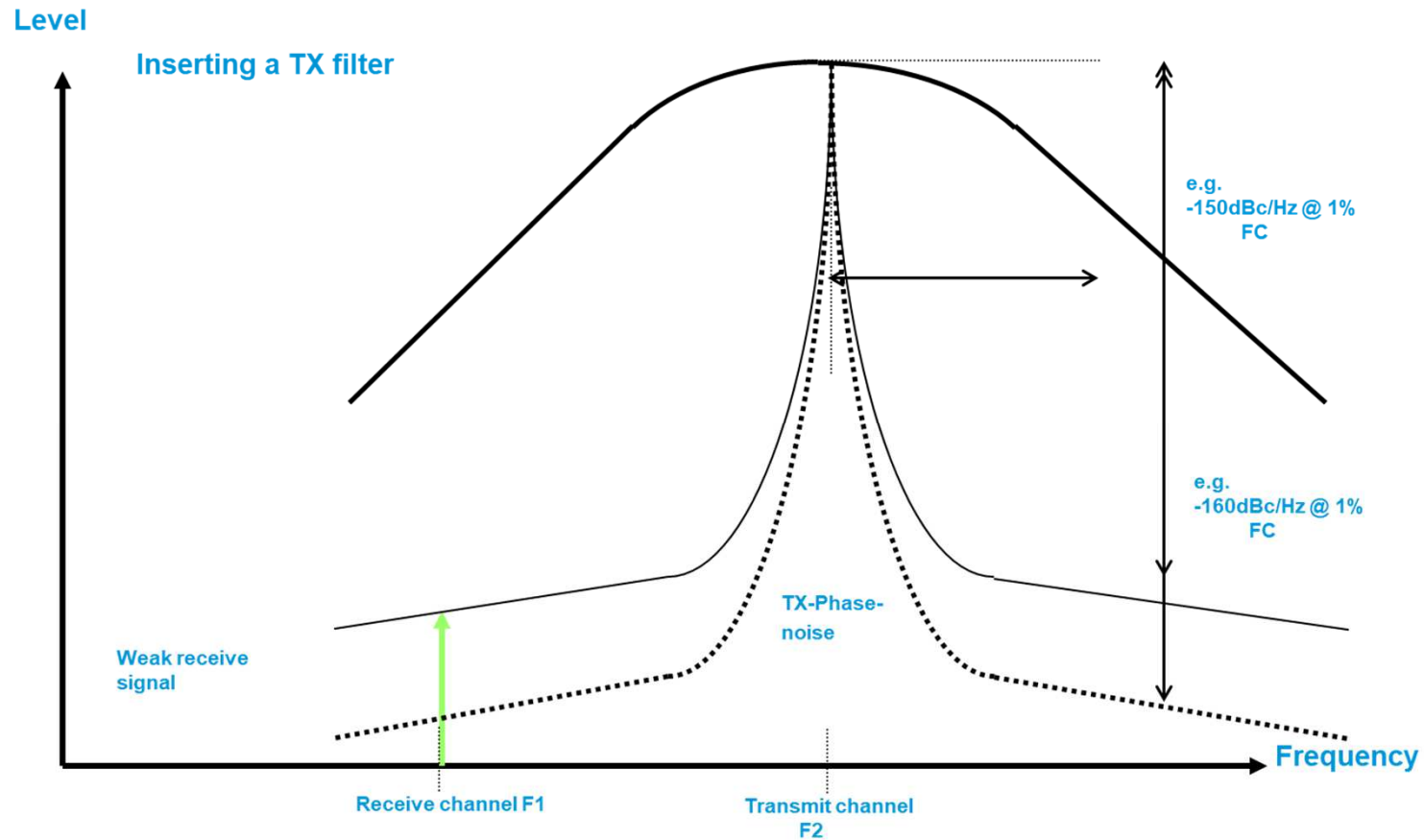

CO-SITE MECHANISMS – RECEIVER DESENSITIZATION

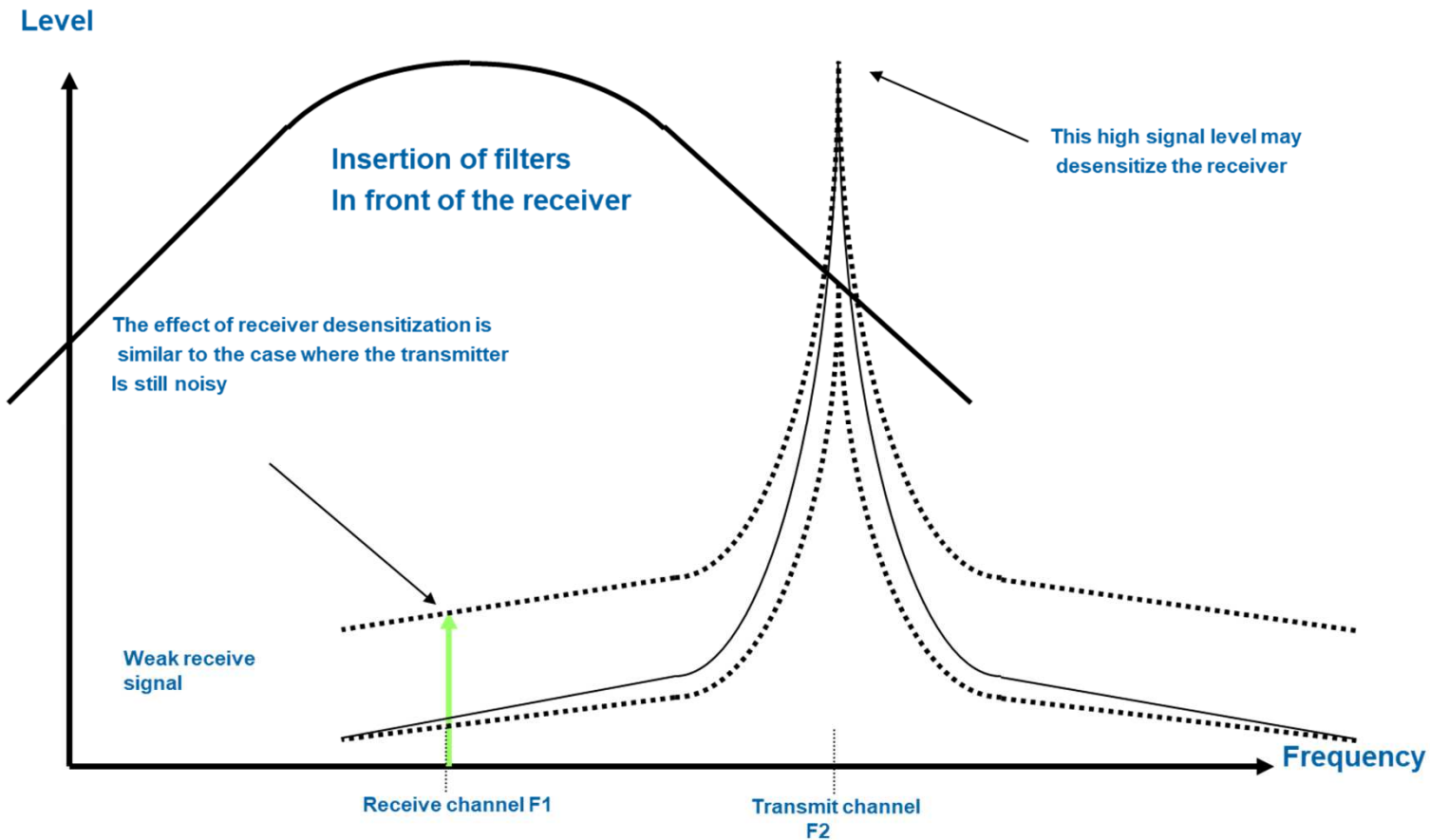

CO-SITE OPERATION – IDEAL RX WITH PRACTICAL TX

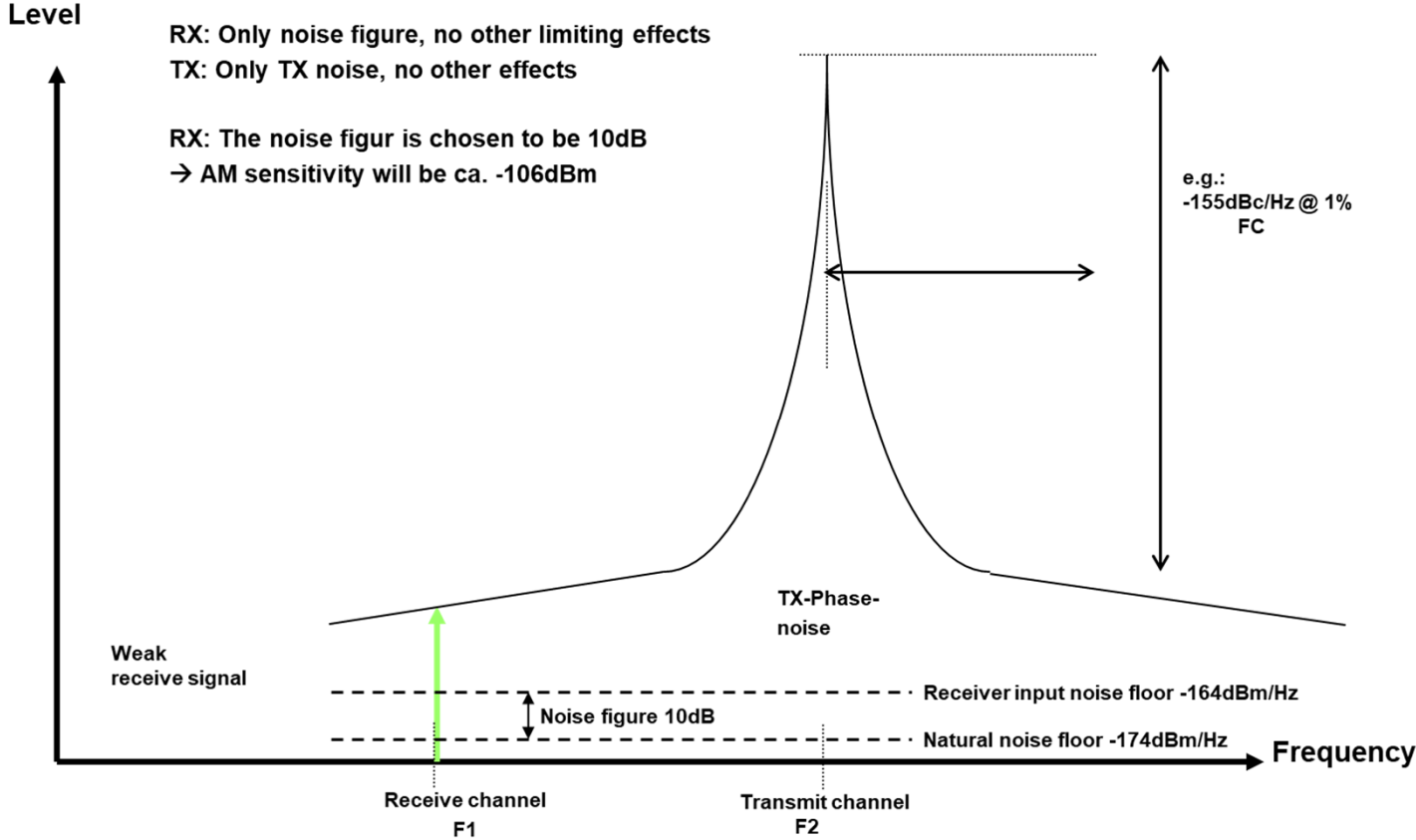

CO-SITE OPERATION – IDEAL RX WITH PRACTICAL TX

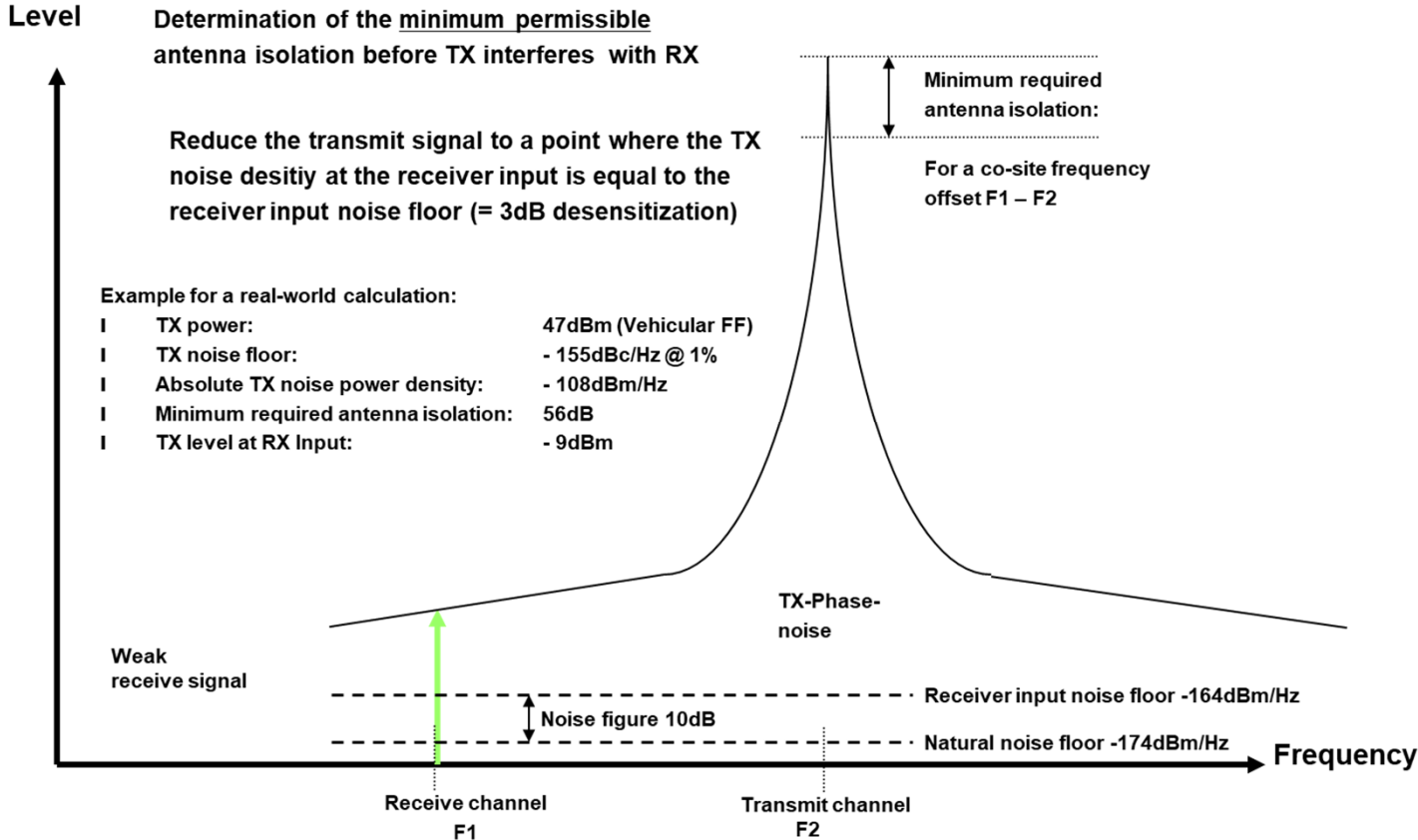

CO-SITE OPERATION – IDEAL RX WITH PRACTICAL TX DISPLAY OF ANTENNA ISOLATION VERSUS CO-SITE FREQUENCY OFFSET

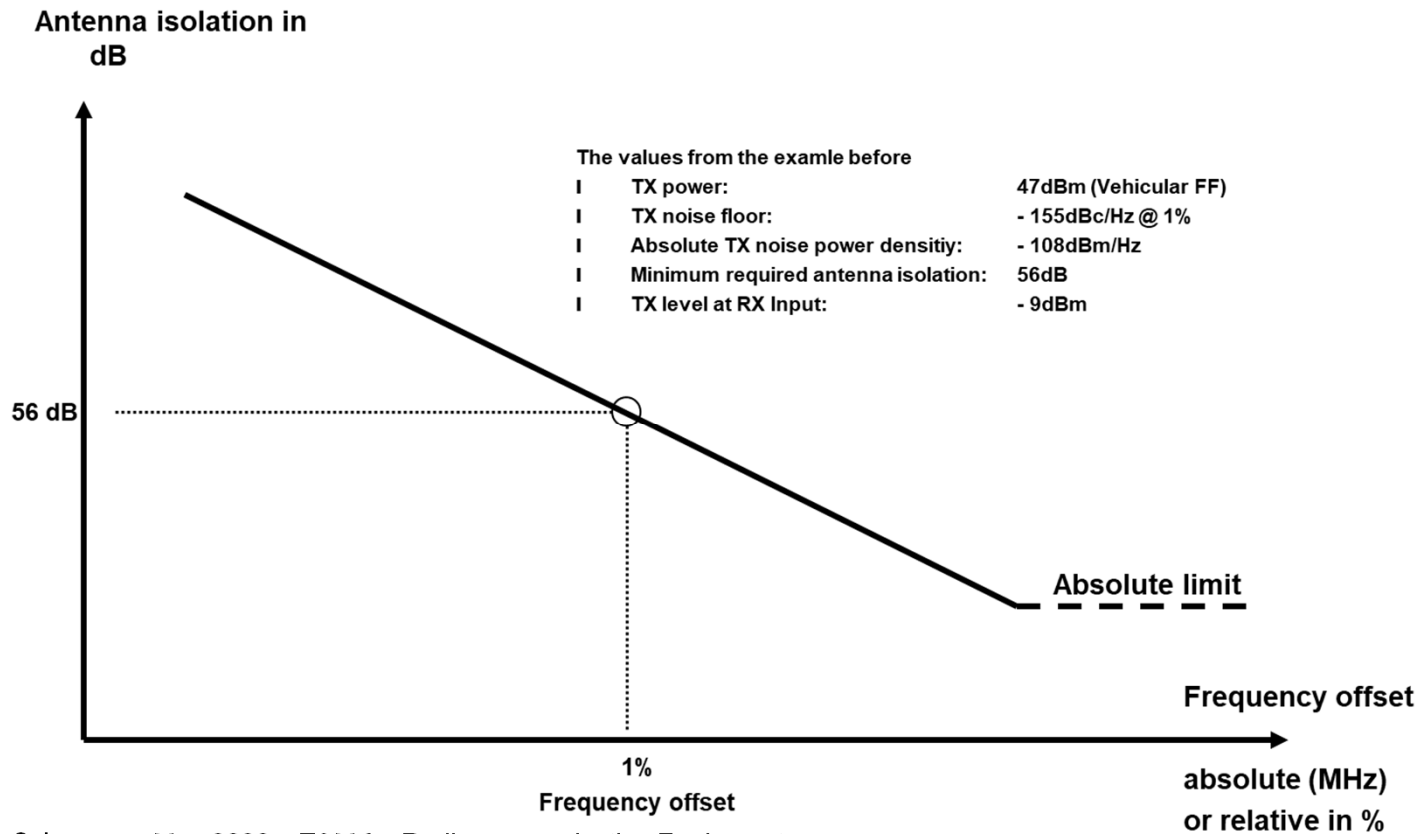

CO-SITE OPERATION IN REALITY

PRACTICAL RX WITH PRACTICAL TX

Now we add RX desensitization (reciprocal mixing) to the example:
Assumption: LO generation with same method as TX signal generation

Points from numerical example:

I TX power:	47dBm (Vehicular FF)
I TX noise floor:	- 155dBc/Hz @ 1%
I Absolute TX noise power density:	- 108dBm/Hz
I Minimum required antenna isolation:	56dB
I TX level at RX Input:	- 9dBm
I New: RX Desensitization:	100dB

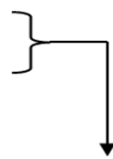

This means for the receiver alone:

- I without TX noise it can receive 100dB below a close-in interferer of -9dBm,
- I The receiver may receive up to -109dBm (if its own noise figure is sufficiently low!)

Conclusion:

- I The receiver reaches a sensitivity of -106dBm as determined by its 10 dB noise figure
- I With TX noise and antenna isolation in this example, the sensitivity drops to -103dBm (3dB less)
- I Desensitization effects may allow a sensitivity of -109dBm
- I → The minimum allowed antenna isolation is determined by TX noise (RX effects are lower)

CO-SITE OPERATION – IDEAL RX WITH PRACTICAL TX DISPLAY OF ANTENNA ISOLATION VERSUS CO-SITE FREQUENCY OFFSET

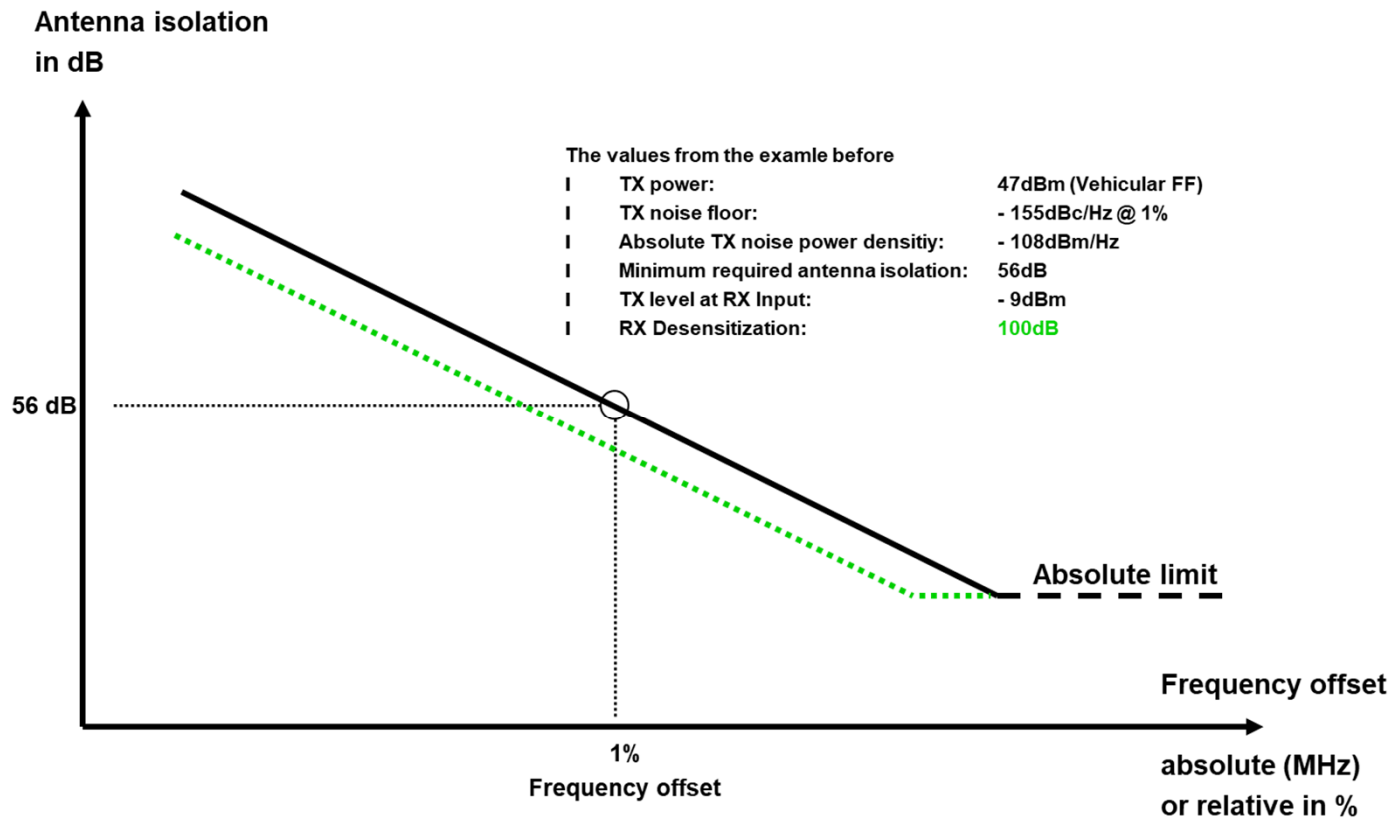

REFERENCES

- A. Farson, “Noise Power Ratio (NPR) Testing of HF Receivers”:
https://www.ab4oj.com/test/docs/npr_test.pdf
- A. Farson, “A New Look at SDR Testing”:
<https://www.ab4oj.com/sdr/sdrtest2.pdf>
- U.L. Rohde, J. Whitaker, H. Zahnd: “Communications Receivers”, 4th Edition, Chapter 11, Sections 11.5, 11.6, 11.7
- ▶ ITOP 6-2-242 FR/GE/US Analog Communication Transmitter and Receiver Test Procedures

THANK YOU FOR YOUR ATTENTION